

**BOARD OF COUNTY COMMISSIONERS  
 JASPER COUNTY, GEORGIA  
 REGULAR MEETING AGENDA  
 \*\*\*\*COMMISSIONERS MEETING ROOM GROUND FLOOR\*\*\*\*  
 MONTICELLO, GEORGIA**

November 1, 2021

6:00 p.m.

**\*\*\* The meeting will be live streamed Via Facebook on the Jasper County Georgia Facebook Page.**

**\*\*\*See Revised Continued Precautions in Response to Covid-19 at bottom of Page 2.**

**\*\*\* Citizen Access will be available with limited Seating. \*\*\***

<b>I. Call to Order (6:00 p.m.)</b>				
NAME	PRESENT	ABSENT	LATE	ARRIVED
DISTRICT 1 – SHEILA G. JONES	<input type="checkbox"/>	<input type="checkbox"/>	<input type="checkbox"/>	
DISTRICT 2 – BRUCE HENRY, CHAIR	<input type="checkbox"/>	<input type="checkbox"/>	<input type="checkbox"/>	
DISTRICT 3 – DON JERNIGAN	<input type="checkbox"/>	<input type="checkbox"/>	<input type="checkbox"/>	
DISTRICT 4 – GERALD STUNKEL – VICE-CHAIR	<input type="checkbox"/>	<input type="checkbox"/>	<input type="checkbox"/>	
DISTRICT 5 - STEVEN LEDFORD	<input type="checkbox"/>	<input type="checkbox"/>	<input type="checkbox"/>	

**II. Pledge of Allegiance –**

**III. Invocation – District 3**

**IV. Approval of Agenda**

**V. Consent Agenda –**

1. Approval of Minutes:
  - October 4, 2021 – Regular Meeting Minutes
2. Check Register – Check #'s **62740 - 62949**

**VI. Public Hearing**

*Public Hearings are conducted to allow public comments on specific advertised issues such as rezoning, ordinances, policy development and other legislative actions to be considered by the County Commissioners. Following the public hearing, the Board of Commissioners will take action on each item presented below.*

**VII. Presentations/Delegations**

*Presentation/Delegations allows scheduled speakers to address the Commission for not more than ten (10) minutes on specific topics or for recognition of citizens, county employees or other events by the Commissioners.*

**Senior Center Director Introduction**

**VIII. Citizens Comments**

*The Citizens Comments section of the Agenda allows citizens who sign up to address the Commission for not more than three (3) minutes on specific topics. The County Attorney will keep time. Please be courteous of the 3 minute time limit. Comments noted from citizens via the Jasper County FB Page.*

**IX. County Commissioner Items**

## X. Regular Agenda

### Business Items:

1. Jasper County Board of Health Appointment
2. Jasper County Recreation Board Appointment
3. CGEMC Agreement for Expediting Expansion of High Speed Internet Service
4. Revenue Sharing Agreement – Stanton Springs and Stanton Springs North
5. 2022 LMIG Application Project Approval
6. Fire Rescue Department – Request for New Ambulance
7. 2021 Capital Improvements Element Annual Update
8. Open New Bank Account for the Food Bank - 2021 CDBG Grant
9. FY 2022 1<sup>st</sup> Quarter Financial Report
10. Schedule Work Sessions and Called Meetings as Needed

## XI. County Attorney Items

## XII. County Manager Update

## XIII. Executive Session

Consultation with County attorney to discuss pending or potential litigation as provided by O.C.G.A. §50-14-2(1); Discussion of the future acquisition of real estate as provided by O.C.G.A. §50-14-3(4); and discussion on employment, compensation, or periodic evaluation of county employees as provided in O.C.G.A. § 50-14-3(6)

*TO BE HELD*

## XIV. Adjournment

### \*\*\*\*Details for Meeting Attendance\*\*\*\*

- All persons will be temperature checked at the door.
- Temperature readings of 100.4 or higher will not be allowed to enter the building.
  - Masks will be provided and recommended to be worn, but not required.
  - Seating will be Limited.

**Jasper County Board of Commissioners**  
**October 4, 2021**  
**Regular Meeting Minutes**  
**6:00 P.M.**

Chairman Henry called the meeting to order at 6:00 p.m.

Commissioners Present: Bruce Henry, Chairman, Gerald Stunkel, Vice-Chairman, Don Jernigan, Sheila Jones and Steven Ledford.

Staff Present: Mike Benton, County Manager, and David Ozburn, County Attorney.

**Pledge of Allegiance:**

**Invocation:** Jasper County Charter School Superintendent Kenny Garland

**Agenda Approval:** Commissioner Stunkel motioned to approve the agenda as presented. Commissioner Ledford seconded the motion, passed unanimously.

**Item 1: Joint Development Authority Revenue Sharing Agreement:** David Ozburn gave an update of where we are with the JDA. Jasper County was in a unique position since it does not have any soil in the area for the JDA. The 2016 JDA Revenue Agreement stated that the BOC and the BOE would come up with an agreement on how funds will be disbursed.

Chairman Henry stated that the two boards came together on September 17<sup>th</sup> to come up with an agreement. The two boards decided on a 60/40 split. BOC will get 60% and the BOE will get 40%.

Commissioner Ledford motioned to authorize Chairman Henry to sign the Intergovernmental Contract regarding JDA Revenue received by Jasper County, Georgia between the parties, Jasper County Board of Commissioners and the Jasper County Board of Education. Commissioner Jernigan seconded the motion, passed unanimously.

**Item 2: Redistricting:** Chairman Henry stated that the redistricting process is going on right now. We would like to keep the BOE districts in line with the Board of Commissioners districts to lessen any confusion.

**Recess**

Commissioner Stunkel motioned to go into recess. Commissioner Jernigan seconded the motion, passed unanimously.

Commissioner Jernigan motioned to go back into session. Commissioner Jones seconded the motion, passed unanimously.

**Consent Agenda:**

Commissioner Stunkel motioned to approve the minutes for September 13, 2021 and September 17, 2021 as presented. Commissioner Jernigan seconded the motion, passed unanimously.

Commissioner Jernigan motioned to approve Check Register Check #s- 62636-62739. Commissioner Ledford seconded the motion, passed unanimously.

**Public Hearing: None**

**Presentations/Delegations-** Commissioner Jones read aloud the Proclamation for St. John CME church.

Commissioner Ledford motioned to approve the proclamation. Commissioner Jernigan seconded the motion, passed unanimously.

**Citizens Comments:**

**Sandra Carter-** Ms. Carter stood before the board to say thank you for the proclamation for St. John C.M.E Church.

**County Commissioner's Items:**

**Commissioner Ledford-** None

**Commissioner Stunkel-** None

**Commissioner Jernigan-** None

**Commissioner Jones-** None

**Chairman Henry-** Chairman Henry made everyone aware that the Food Bank received the CDBG grant. He stated that he met with Ken Horton and they are getting the wheels rolling on the project.

**Regular Agenda:**

**Item 3: C&D Landfill- Five Year Design & Operational Plan Update- TPE Fee Proposal:** Mike Benton introduced Tony Rodriguez of Triple Point Engineering. Mr. Rodriguez gave the five year update. He stated that all solid waste landfills are required to update every five years. The deadline for the renewal is January 31, 2022. The existing D &O plan has to be updated with the current topography. Everything in the plan has to be updated to the current requirements. Once the D & O is updated and submitted the EPD will review it and approve it. It takes them a while to review the plans. We will work under the current plan until the update is approved.

Commissioner Stunkel motioned to authorize Chairman Henry to sign Triple Point Engineering's Scope of Services and Fee Proposal for the Five Year Design & Operational Plan Updated as presented. Commissioner Ledford seconded the motion, passed unanimously.

**Item 4: 2022 LMIG Project & Application:** Chairman Henry stated that we have money coming in and we have to decide which road we will work on.

Robert Jordan stood before the board to share information about our Road Ranking System. Based on our system Jackson Lake Road has the most serious need. It needs widening, and paving. The shoulders are deteriorating.

Mike Benton suggested that the board approve Jackson Lake Road as the project for the LMIG.

Commissioner Jernigan stated that if we know that it is going to take two years of LMIG we should do the approval now for both LMIG years.

Commissioner Stunkel motioned to assign the section of Jackson Lake Road from SR 11 North to SR 212 West as the project for the 2022 LMIG Program with Jordan Engineering developing cost estimates with resurfacing and widening options and presenting back to the BOC. Commissioner Jernigan seconded the motion, passed unanimously.

**Item 5: FY 2021 Year End Budget Amendments:** Dennis Pate stood before the board to present a request for year-end budget amendments for the Planning and Zoning Department. Planning and Zoning department experienced increased expenses for professional services as a result of the increasing volume of building permits. However, the increased expense is offset by increased revenues received by the planning and zoning department during FY2021.

Commissioner Ledford motioned to approve FY 2021 budget amendment for Planning and Zoning as presented. Commissioner Jernigan seconded the motion, passed unanimously.

**Item 6: Schedule Work Sessions and Called Meetings:** The board has a Work Session scheduled for Monday, October 25, 2021 for CIE Update Discussion and JDA Fund Planning.

**County Attorney Items:**

None, but would like an Executive Session for potential litigation.

**County Manager Items:** Mike Benton stated that we have our new Senior Center Director. Pittman stated that they plan to start next Wednesday. Once they have completed Post Road they will move to Pintail. Right away tree limbing will be done by a local company as a trial. They will be working on Jackson Lake Road in one of the worst areas that need attention. They are looking at October 21-22.

Michael Walsh stated that they have signage up in Lakeview Estates.

Mike Benton stated that the issue with the siren on Pintail was a computer chip. The chip has been replaced. New Construction permits for the last month were 24 new home permit. Total permits for September were 67.

**Executive Session: None**

**Adjourn:**

Commissioner Ledford motioned to adjourn the meeting at 6:47 p.m. Commissioner Jernigan seconded the motion, passed unanimously.

---

Bruce Henry, Chairman

---

Sharon Robinson, Clerk

**Business Item :**

**Agenda Request – Jasper County BOC**

**Department:** Board of Commissioners

**Date:** November 1, 2021

**Subject:** Jasper County Board of Health Appointment

**Summary:**

Carole Norris's term on the Jasper County Board of Health will expire in December.

Carole Norris has agreed to serve another term on the Board from January 1, 2022 to December 31, 2027.

**Background:**

Jasper County Health Department Board of Directors has seven members.

Jasper County BOC appoints three members to the Jasper County Board of Health

**Cost:**

None

**Recommended Motion:**

Appoint Carole Norris to Jasper County Health Department Board for the term January 1, 2022 through December 31, 2027.

Applicant Name: Carole Norris

Date: 8-27-21

I would like to apply for appointment to the following Board, Committee, or Authority:

Board of Health

How long have you been a resident of Jasper County?

63 yrs

Which Jasper County district do you live in?

(1)     (2)     (3)     (4)     (5)

What qualifications, experience, and certifications do you possess that should be considered for the Board, Committee, or Authority you are seeking appointment on?

have been on this board for the last  
2+ years

Are you currently serving on another Board, Committee, Authority or elected position?  
 Yes     NO    If Yes, please list.

Would there be any possible conflict of interest between your employment, your family, or your serving on the Board, Committee, or Authority you are seeking appointment on?

Yes     NO    If Yes, please explain.

What is your vision for the county's future in relation to the Board, Committee, or Authority you are seeking appointment on?

Current term is Consumer to represent  
needy and underprivileged and elderly.  
To make sure these people have representation

Explain your understanding of the duties of this Board, Committee, or Authority:

Attend meetings to make sure  
everyone is included

Briefly explain why you seek appointment to this Board, Committee, or Authority:

To be reappointed

Are you in any way related to a County Elected Official or County Employee? If so, please describe.

County Employee myself

If appointed, I agree to serve and participate in required and or voluntary training.  Yes  No

  
Signature

8/27/21  
Application Date



## Board of Health Member Expiration Notice

From: Borel, Tiffany (tiffany.borel@dph.ga.gov)

To: norris\_w@bellsouth.net

Cc: djernigan@jaspercountyga.org; renee.haynes@dph.ga.gov; sherry.bryant@dph.ga.gov; lauren.nation@dph.ga.gov

Date: Thursday, August 19, 2021, 10:03 AM EDT

Good afternoon Ms. Norris,

This email is to remind you that your current term; as the Consumer to Represent the Needy, Underprivileged, or Elderly, appointed by the County Commissioners, on the Jasper County Board of Health will expire on December 31, 2021.

Please contact the Jasper County Board of Commissioners to discuss interest in reappointment for the next term of January 1, 2022-December 31, 2027.

The North Central Health District would like to thank you for your contributions to the community, Jasper County Board of Health, and North Central Health District.

Sincerely,  
Tiffany Borel



### **Tiffany Borel**

DHD Administrative Assistant/Board of Health Liaison  
North Central Health District  
201 Second St., Suite 1100  
Macon, GA 31201  
Office: 478-751-6247  
Cell: 478-508-7314  
Fax: 478-751-6099  
[tiffany.borel@dph.ga.gov](mailto:tiffany.borel@dph.ga.gov)

*I would be  
interested in  
going back on  
Carole*

To report public health emergencies after-hours, call 1-866-PUB-HLTH.

Reader Advisory Notice: Email to and from a Georgia state agency and/or County Board of Health is generally public record, except for content that is confidential under specific laws. Security by encryption is applied to all confidential information sent by email from the Georgia Department of Public Health (DPH) and/or County Board of Health. This message is only intended for specific recipient(s) and may contain privileged, private or sensitive information. If you received this message in error, please delete it and contact me.

**Business – Item :**

**Agenda Request – Jasper County BOC**

**Department:** Recreation

**Date:** November 1, 2021

**Subject:** Jasper County Recreation Board Appointment

**Summary:**

Jasper County Recreation Board has 2 vacancies that need to be filled. The following people have expressed interest in serving on the Board:

Catherine Kendall

Robert Rosser

**Background:**

The Jasper County Recreation Board is a seven (7) member board

**Cost:** None

**Recommended Motion:**

Appoint Catherine Kendall and Robert Rosser to the Jasper County Recreation Board for a 3-year term ending November 2024.

Applicant Name: Catherine Kendall

Date: 10/19/21

I would like to apply for appointment to the following Board, Committee, or Authority:

Rec Center

How long have you been a resident of Jasper County?

3 yrs

Which Jasper County district do you live in?

     (1)

(2)

     (3)

     (4)

     (5)

What qualifications, experience, and certifications do you possess that should be considered for the Board, Committee, or Authority you are seeking appointment on?

I have 8 yrs experience with the ice cream truck all ages of kids and adult, with that I learned how to understand and deal with

all types of kids and adult, also hosting events and

parties and school event. also 5 yrs experience in the child care field. I feel I have gain the ~~knowledge~~ understanding and skill that qualified me

Are you currently serving on another Board, Committee, Authority or elected position?

     Yes  NO If Yes, please list.

Would there be any possible conflict of interest between your employment, your family, or your serving on the Board, Committee, or Authority you are seeking appointment on?

     Yes  NO If Yes, please explain.

**What is your vision for the county's future in relation to the Board, Committee, or Authority you are seeking appointment on?**

Bring more events, fundraisers, and activities for the kids and youth of Jasper County and also being a part of the community

**Explain your understanding of the duties of this Board, Committee, or Authority:**

Volunteering and bring ideas and being part of the community

**Briefly explain why you seek appointment to this Board, Committee, or Authority:**

playing/being a part of the community  
Bring more things for the youth and kids of Jasper County

**Are you in any way related to a County Elected Official or County Employee? If so, please describe.**

No

If appointed, I agree to serve and participate in required and or voluntary training.  Yes  No

  
Signature

10/19/21  
Application Date

Robert Rosser

I would like to apply for appointment to the following Board, Committee, or Authority:

Recreation Board

How long have you been a resident of Jasper County?

lifetime . 34 years

Which Jasper County district do you live in?

     (1)    X (2)         (3)         (4)         (5)

What qualifications, experience, and certifications do you possess that should be considered for the Board, Committee, or Authority you are seeking appointment on?

The recreation department deals with sports and kids. I am a college athlete who works at the Primary School. I am versed in most sports and have an excellent rapport with the kids.

Are you currently serving on another Board, Committee, Authority or elected position?         Yes    X NO    If Yes, please list.

\_\_\_\_\_  
\_\_\_\_\_

Would there be any possible conflict of interest between your employment, your family, or your serving on the Board, Committee, or Authority you are seeking appointment on?

     Yes    X NO    If Yes, please explain.

\_\_\_\_\_  
\_\_\_\_\_  
\_\_\_\_\_

What is your vision for the county's future in relation to the Board, Committee, or Authority you are seeking appointment on?

I want to see Monticello Athletics become respected and by growing cover in talent, knowledge, facilities and availability. That starts at the rec.

Explain your understanding of the duties of this Board, Committee, or Authority:

To seek the betterment of our Kids, facilities, programs and families through the real world applications that are often made through sports.

Briefly explain why you seek appointment to this Board, Committee, or Authority:

I see what Jasper County could be. Growing up & playing here my heart is for this community. I want my son's <sup>athletic</sup> future to be brighter than my athletic past.

Are you in any way related to a County Elected Official or County Employee? If so, please describe.

~~Yes~~ I am - Jasper County Board of Education  
my sister Jasper County Sheriff's Department

If appointed, I agree to serve and participate in required and or voluntary training.  Yes  No



Signature

10-18-21

Application Date

## **Agenda Request – Jasper County BOC**

**Department:** Board of Commissioners

**Date:** November 1, 2021

**Subject:** CGEMC Agreement for Expediting Expansion of High Speed Internet Service

### **Summary:**

Central Georgia Electric Membership Corporation plans to extend high speed internet service along its existing electric lines.

### **Background:**

The BOC at its May 3, 2021 regular meeting approved investing \$900,000 with Central Georgia EMC to expedite expansion of high speed broadband service to Jasper County residents served by the CGEMC.

### **Cost:**

\$900,000

Funding Source – American Rescue Plan Funds

### **Recommended Motion:**

Authorize Chairman to sign the “Agreement for Expediting Expansion of High Speed Internet Service to Jasper County, Georgia” between Jasper County BOC and Central Georgia Electric Membership Corporation.

JASPER COUNTY, GEORGIA

**AGREEMENT FOR EXPEDITING EXPANSION OF HIGH SPEED INTERNET SERVICE TO JASPER COUNTY, GEORGIA**

THIS AGREEMENT is made this \_\_\_\_\_, 2021, between Jasper County, Georgia ("County"), a political subdivision of Georgia, and Central Georgia Electric Membership Corporation, a corporation organized under the laws of the State of Georgia, whose principal office is located in Jackson, Georgia (hereinafter called the Corporation).

WHEREAS, the County and the Corporation strive for a good working relationship that will benefit all customers of the Corporation who reside in the County; and

WHEREAS, the Corporation currently plans to extend high speed internet services along its existing lines within the County and offer said internet services to its customers; and

WHEREAS, County is desirous to promote efforts to make available high speed internet service to its citizens; and

WHEREAS, the Corporation is confident that if County provides the funds totaling \$900,000.00 as outlined herein, it shall complete the installation of equipment necessary to provide high-speed internet access to its customers located in Jasper County sometime during the third quarter of 2023; and

WHEREAS, the Corporation can expedite it's installation of high speed internet according to the installation schedule herein if the County contributes funds to defray installation costs according to the payment schedule herein; and

NOW THEREFORE, for valuable consideration and mutual promises between the parties hereto, in consideration of the promises, and in compliance with and pursuant to the provisions, terms, and conditions of the statutes pertaining thereto, the parties hereby contract with each other to promote the expedited installation of high-speed internet access to citizens of Jasper County who are customers of the Corporation, as follows:

1. The above preamble is incorporated herein. This Agreement shall be binding on the parties immediately and terminating on the schedule included herein.

2. County shall provide payment according to the below schedule to the Corporation. This payment shall be funded through County's general fund.

3. The Corporation shall complete any and all work necessary to offer high-speed internet to its customers in Jasper County by the date indicated in the below schedule and shall certify the percentages of the total project completed to the County at each indicated interval. If it appears to the County that there is no appreciable progress or that progress is substantially lower than the expected percentages as described in the Payment Schedule, the County shall consult with the Corporation prior to withholding any scheduled payments.

4. The Corporation will start field engineering activity by December of 2021 with construction activity to begin by April of 2022.



## 5. Payment Schedule

Date	Payment	Work Certified Complete*
2 <sup>nd</sup> Quarter 2023	\$450,000.00	50%
3 <sup>rd</sup> Quarter 2023	\$450,000.00	100%

\*Work completion percentage correlates with percentage of Central Georgia EMC customers who are eligible to schedule in-home installations due to completion of main-line fiber infrastructure.

## 6. Penalty for Delayed Completion

If Corporation does not complete the work necessary to provide access to high-speed internet to its Jasper County customers by the end of the 3<sup>rd</sup> quarter of 2023, the total payment from the County shall be decreased by \$30,000.00 per month thereafter until the work by Corporation is completed.

## 7. Miscellaneous Legal Provisions.

All disputes arising under this Agreement shall be litigated in the Superior Court of Jasper County, Georgia.

This agreement shall continue in effect from year to year until terminated by any of the parties, who shall give notice in writing in accordance herewith per the laws of Georgia.

This Agreement may not be modified except by written instrument signed by the parties. This Agreement supersedes all prior discussions and agreements between the parties and contains the sole and entire understanding between the parties with respect to transactions contemplated by this Agreement. All promises, inducements, offers, solicitations, agreements, representations and warranties heretofore made between the parties, if any, are superseded.

Except as expressly limited by this Agreement, all rights, powers and privileges conferred hereunder shall be cumulative and not restrictive of those provided at law or in equity.

No failure of any party to exercise any power given under this Agreement or to insist upon strict compliance with any obligation specified in this Agreement, and no custom or practice at variance with the terms of this Agreement, shall constitute a waiver of any party's right to demand exact compliance with the terms of this Agreement.

All notices, requests, demands or other communications required or permitted to be given hereunder shall be in writing and shall be addressed and delivered to each party at the addresses below. Any such notice, request, demand or other communication shall be considered given or delivered, as the case may be, on the date of receipt. Rejection or other refusal to accept or inability to deliver because of changed address of which proper notice was not given shall be deemed to be receipt of the notice, request, demand or other communication. By giving prior written notice thereof, any party may from time to time and at any time change its address for notices hereunder. Legal counsel for the respective parties may send to the other party any notices, requests, demands or other communications required or permitted to be given hereunder

by such party.

On and after the date of this Agreement, the parties shall, at the request of the other, make, execute and deliver or obtain and deliver all instruments and documents and shall do or cause to be done all such other things which any party may reasonably require to effectuate the provisions and intentions of this Agreement.

This Agreement shall be construed without regard to the identity of the person who drafted the various provisions hereof. Each provision of this agreement shall be construed as though all the parties participated equally in its drafting. Consequently, the parties acknowledge and agree that any rule of construction that a document is to be construed against the drafting party shall not be applicable to this Agreement.

If any provision of this Agreement is held unenforceable such provision shall be fully severable. The Agreement shall be construed and enforced as if such unenforceable provision had never comprised a part hereof, and the remaining provisions shall remain in full force.

The signatories state they have the authority to bind the party on whose behalf they are signing.

APPROVED AND ACCEPTED:

For Central Georgia Electric  
Membership Corporation

For Board of Commissioners of Jasper County

By: \_\_\_\_\_  
(signature)

By: \_\_\_\_\_  
(signature)

Name: \_\_\_\_\_  
(type or print)

Name: \_\_\_\_\_  
(type or print)

Title: \_\_\_\_\_  
[SEAL]

Title: \_\_\_\_\_  
[SEAL]

Witness: \_\_\_\_\_

Attest: \_\_\_\_\_  
County Clerk

**Agenda Request – Jasper County BOC**

**Department:** Board of Commissioners

**Date:** November 1, 2021

**Subject:** Revenue Sharing Agreement – Stanton Springs and Stanton Springs North

**Summary:**

Stanton Springs and Stanton Springs North Revenue Sharing Agreement to be Presented for Approval.

**Background:**

**Cost:**

**Recommended Motion:**

Authorize Chairman to sign the Resolution to Approve and the Amended and Restated Intergovernmental Contract “Revenue Sharing Agreement for Stanton Springs and Stanton Springs North”.

**AMENDED AND RESTATED  
INTERGOVERNMENTAL CONTRACT  
RE: REVENUE SHARING AGREEMENT FOR STANTON SPRINGS AND STANTON  
SPRINGS NORTH**

THIS INTERGOVERNMENTAL CONTRACT (“Contract”), made and entered into as of the \_\_\_\_ day of \_\_\_\_\_, 2021 by and between JASPER COUNTY, GEORGIA, a political subdivision of the State of Georgia, MORGAN COUNTY, GEORGIA, a political subdivision of the State of Georgia, NEWTON COUNTY, GEORGIA, a political subdivision of the State of Georgia, WALTON COUNTY, GEORGIA, a political subdivision of the State of Georgia (collectively the “Counties”), the CITY OF SOCIAL CIRCLE, a political subdivision of the State of Georgia (the “City”), the JOINT DEVELOPMENT AUTHORITY OF JASPER COUNTY, MORGAN COUNTY, NEWTON COUNTY AND WALTON COUNTY, a public body corporate and politic of the State of Georgia (the “Authority”), and JASPER COUNTY SCHOOL DISTRICT, a public body corporate and politic of the State of Georgia, MORGAN COUNTY SCHOOL DISTRICT, a public body corporate and politic of the State of Georgia, NEWTON COUNTY SCHOOL DISTRICT, a public body corporate and politic of the State of Georgia, WALTON COUNTY SCHOOL DISTRICT, a public body corporate and politic of the State of Georgia, and CITY OF SOCIAL CIRCLE SCHOOL DISTRICT, a public body corporate and politic of the State of Georgia (collectively the “School Districts”) and between JASPER COUNTY BOARD OF TAX ASSESSORS, MORGAN COUNTY BOARD OF TAX ASSESSORS, NEWTON COUNTY BOARD OF TAX ASSESSORS, WALTON COUNTY BOARD OF TAX ASSESSORS (collectively the “BOAs”), and JASPER COUNTY TAX COMMISSIONER, MORGAN COUNTY TAX COMMISSIONER, NEWTON COUNTY TAX COMMISSIONER and the WALTON COUNTY TAX COMMISSIONER, (collectively the “Tax Commissioners”).

**WITNESSETH:**

**WHEREAS**, on October 18, 2000, the Authority acquired an approximately 1,528-acre site which has been expanded to now total approximately 1,635 acres, which site is located in Morgan, Newton, and Walton Counties, in order to proceed with the development of a research park known as Stanton Springs; and

**WHEREAS**, to acquire the Property, the Authority issued, and the Counties agreed to make debt service payments on, taxable adjustable revenue bonds in the amount of \$9,000,000.00 (the “Bonds”);

**WHEREAS**, by separate intergovernmental contracts dated October 1, 2000, the Counties agreed to make debt service payments on the Bonds based on the following percentages:

Jasper County	10.0%
---------------	-------

Morgan County	15.0%
Newton County	37.5%
Walton County	37.5%;

**WHEREAS**, on May 27, 2021, the Authority acquired an approximately 665-acre site located north of Interstate 20 which lies in part in the Walton County, the City of Social Circle and Morgan County to proceed with the development of an industrial park known as Stanton Springs North; and

**WHEREAS**, Article IX, Section III, Paragraph I(a) of the Georgia Constitution authorizes, among other things, any county, municipality, or other political subdivision of the State to contract for a period not exceeding fifty years, with any other public agency, public corporation, or public authority for joint services, for the provision of services, or for the provision or separate use of facilities or equipment, provided that such contract deals with activities, services or facilities which the contracting parties are authorized by law to undertake or provide; and

**WHEREAS**, Article IX, Section IV, Paragraph IV of the Georgia Constitution authorizes counties and municipalities to enter into contracts with other counties and municipalities for the purpose of allocating the proceeds of ad valorem taxes assessed and collected on property located in such county or municipality with such other counties or municipalities with which the assessing county or municipality has entered into agreements for the development of one or more regional facilities and the allocation of other revenues generated from such regional facilities, and that such a contract shall provide for the manner of development, operation and management of the regional facility and the sharing of expenses among the contracting local governments and shall specify the method of allocation and the percentage of ad valorem taxes and other revenues to be allocated to each contracting local government; and

**WHEREAS**, On December 2, 2004, the Authority and the Counties entered into an Intergovernmental Contract (“2004 Contract”) which, among other things, specified the distribution of revenues, tax payments and payments in lieu of taxes collected on or in connection with the Stanton Springs;

**WHEREAS**, On September 20, 2016, the Authority, Counties and School Districts entered into an Intergovernmental Contract (“2016 Contract”) which superseded the 2004 Contract and provided clarity on the procedures, rights, and obligations for sharing tax revenue and other revenues generated from Stanton Springs; and

**WHEREAS**, as a result of the implications of the 2016 Contract on the Counties’ tax digests, amendments to O.C.G.A. §36-62-5.1 and §48-5-274 were required and made by House Bill 406, to ensure the tax digests of the Counties accurately reflected each County’s portion of the property value in Stanton Springs and Stanton Springs North; and

**WHEREAS**, implementation of the 2016 Contract and House Bill 406 require close coordination and uniform procedures between the Boards of Tax Assessors and Tax Commissioners of each County and City which resulted in Procedure Manuals being

independently adopted by the County Board of Tax Assessors and Tax Commissioners from each County in 2020; and

**WHEREAS**, on May 18, 2021, the Authority and Social Circle entered into an Intergovernmental Contract regarding Stanton Springs North underwhich the Authority agreed to initiate a revision of the 2016 Contract to account for tax revenue division for property in Stanton Springs North; and

**WHEREAS**, the parties desire to amend the 2016 Contract to incorporate the addition of Stanton Springs North, the City of Social Circle and the Social Circle School District, account for the requirements of House Bill 406, and define the procedures, rights and obligations associated with sharing tax revenue and other revenues generated therein with all parties; and

**WHEREAS**, for clarity, this Agreement shall supersede the 2004 Contract and the 2016 Contract.

**NOW THEREFORE**, for and in consideration of the premises and undertakings as hereinafter set forth and other good and valuable consideration, the receipt and sufficiency of which are hereby acknowledged, the Authority, City, Counties, Board of Tax Assessors, Tax Commissioners and School Districts HEREBY AGREE as follows:

1:

The preamble and recitals above make up a part of the terms, conditions and provisions of this Contract.

2.

This Contract shall become effective upon execution by all parties and shall continue in effect for fifty (50) years.

3.

#### **Definitions**

- a. **Assessing BOA:** The Board of Tax Assessors (“BOA”) of the County in which 51% or more of the land owned or leased by a company within Stanton Springs or Stanton Springs North is located. Walton County’s BOA is the Assessing BOA for Takeda (formerly Baxter, Baxalta and Shire) and for projects with 51% or more land in Walton County or the City of Social Circle. Newton County’s BOA is the Assessing BOA for Facebook (aka Morning Hornet, LLC) and any projects with 51% or more land in Newton County. Morgan County’s BOA is the Assessing BOA for Baymare, LLC and any projects with 51% or more land in Morgan County.
- b. **Assessment Notices:** Annual notices stating the assessed value of property sent to taxpayers.
- c. **Collecting Commissioner:** The Tax Commissioner of the County in which 51% or more of the land owned or leased by a company within Stanton Springs or Stanton Springs North

is located. The Walton County Tax Commissioner is the Collecting Commissioner for Takeda and any projects with 51% or more property in Walton County or the City of Social Circle. The Newton County Tax Commissioner is the Collecting Commissioner for Facebook and any projects with 51% or more property in Newton County. Morgan County Tax Commissioner is the Collecting Commissioner for Baymare, LLC and any projects with 51% or more property in Morgan County.

- d. ***Debt Service Obligations:*** Debt Service Obligations are the Authority's obligations which are currently outstanding and any future debt service obligations incurred by the Authority with the approval of the Counties pursuant to the terms herein. As of the date of this Contract, the Authority has no direct Debt Service Obligations.
- e. ***Expenses:*** Expenses shall be defined as any costs incurred by the Authority as allowed under Georgia law for the development of Stanton Springs and Stanton Springs North plus the sum of reasonable reserves for maintenance, operations, and expenses.
- f. ***House Bill 406:*** HB 406, effective as of May 7, 2019, amended O.C.G.A. § 36-62-5.1 and O.C.G.A. § 48-5-274 to create reporting requirements for the Authority and establish the process for Counties to report shared tax values on their individual tax digests.
- g. ***Net Other Revenues:*** Net Other Revenues are Other Revenues minus the Authority's Expenses and Debt Service Obligations.
- h. ***Net Tax Revenues:*** Net Tax Revenues are Tax Revenues minus the Authority's budgeted Expenses and Debt Service Obligations not otherwise paid from Other Revenues.
- i. ***Other Revenues:*** Other Revenues are revenues generated from the Authority's activities including but not limited to, sales of land, leases of land, sales or leases of personalty, sales of timber or other resources and fees. Other Revenues shall not include any fees specifically allocated to the Authority in connection with a bond issuance.
- j. ***Parcel Identification Numbers:*** Numbers assigned to tax parcels for identification purposes by the BOAs.
- k. ***Payment In Lieu of Taxes ("PILOT") Structure:*** Tax abatement structure applicable to some properties in Stanton Springs or Stanton Springs North where set payments are made by a company over a certain number of years in lieu of paying taxes. Facebook (aka Morning Hornet, LLC) is structured in this way. PILOT payments are made to the JDA and the JDA distributes said payments to the Counties, Cities and School Districts in accordance with the terms herein.
- l. ***Payout Percentage:***
  - a. For Stanton Springs, the payout percentages are: Jasper County – 10%; Morgan County – 15%; Newton County – 37.5%; Walton County – 37.5%.
  - b. For Stanton Springs North, the payout percentages are: : Jasper County – 9.5%; Morgan County – 14.25%; Newton County – 35.625%; Walton County – 35.625%; Social Circle – 5%.
- m. ***Phase-In Lease Valuation Structure:*** Tax abatement structure applicable to some properties in Stanton Springs or Stanton Springs North where a lease valuation schedule determines the percentage of taxes paid by a company each year for a certain number of years until the percentage reaches 100%.

- n. ***Stanton Springs:*** Stanton Springs is approximately 1,635 acres currently located in the development park known as Stanton Springs and is generally bounded by Interstate 20 to the north, Hwy 278 to the west, and private property owners to the east and south including any land added to Stanton Springs in the future which is south of Interstate 20. A general boundary map of Stanton Springs as of the date hereof is attached hereto as Exhibit “A”.
- o. ***Stanton Springs North:*** Stanton Springs North is a new research development park which the Authority may develop. Stanton Springs North will be generally bounded by Interstate 20 to the south and Hwy 278 to the west and will expand to the north and east into both Walton and Morgan Counties. The actual boundaries will be established on a parcel-by-parcel basis as the Authority purchases or otherwise gains control of property. The Authority may designate properties as being in Stanton Springs North by Resolution which includes a boundary map, parcel number(s) and description of the property. A copy of the Resolution with attachments shall be provided to the parties hereto. As of the date hereof, Stanton Springs North consists of approximately 665 acres as shown on the attached Exhibit “B”.
- p. ***Tax Digest:*** The Tax Digest is the list of all properties and values within a County, City or School District.
- q. ***Tax Revenues:*** Tax Revenues are all ad valorem taxes levied by the Counties, City and the School Districts on real and personal property in Stanton Springs and Stanton Springs North. This includes all taxes assessed on fee simple and leasehold interests, board of education taxes, taxes collected for special assessments for specific services, general obligation bonds, and any and all other ad valorem property taxes collected. Tax Revenues shall not include taxes collected by a county department other than the chief tax collector including, but not limited to, sales taxes, insurance premium taxes, intangible taxes, real estate transfer taxes, railroad taxes, franchise fees, occupational taxes, alcohol taxes, and financial institution taxes. Tax Revenues shall also not include ad valorem title taxes on motor vehicles. Tax Revenue shall not include ad valorem taxes collected on behalf of and due the State of Georgia. Finally, Tax Revenues shall not include any penalties or interest collected for late payments; any such penalties and interest shall be retained by the County of the Collecting Commissioner.
- r. ***Tenant:*** a person or entity which owns, or leases from the Authority, any portion of the Property, including the Authority.
- s. ***Tenant Property:*** Tenant Property is the real and personal property owned or leased by a Tenant, including the Authority.

4.

#### **Distribution of Tax Revenues 2004 – 2015**

From 2004 to 2015, Tax Revenues were generated from portions of the Property located in Newton and Walton Counties. Said Tax Revenues were collected by Newton and Walton Counties and distributed in accordance with their millage rates without taking into account the 2004 Contract. Pursuant to the 2016 Contract, Walton County, Newton County and the Newton County School District repaid the amounts due by utilizing their share of the 2020



distribution of taxes generated in Stanton Springs. As of the date hereof, no known reimbursements are due.

5.

**Authority's Obligations**

The Authority hereby agrees as follows:

- a. The Authority shall collect and deposit in a separate account any and all Other Revenues.
- b. The Authority shall collect and deposit in a second separate account any and all Tax Revenues distributed to it by the Collecting Commissioners and any PILOT payments.
- c. The Authority shall pay its Expenses and Debt Service Obligations first from Other Revenues and then from PILOT Payments and then from Tax Revenues.
- d. The Authority shall prepare an operating budget report annually to include its projected Expenses, Debt Obligations, Other Revenues, PILOT Payments and Tax Revenues for the 12-month period from July 1-June 30. The operating budget shall specify the amount of Tax Revenues or PILOT Payments necessary for the Authority to meet its budget requirements for the Authority's Expenses and Debt Service Obligations not otherwise paid by Other Revenues. A copy of said operating budget shall be delivered to the Counties and City on or before the first day of May of each year with a copy to each School District.
- e. The Authority does not have any Debt Service Obligations as of the date hereof. The Counties shall approve all new Debt Service Obligations.
- f. The Authority shall distribute Net Other Revenues for the prior year to the Counties on or before March 15 of each year in accordance with their payout percentages as follows:
  1. Jasper County shall receive 10.0%;
  2. Morgan County shall receive 15.0%;
  3. Newton County shall receive 37.5%; and
  4. Walton County shall receive 37.5%.
- g. The Authority shall distribute PILOT Payments received for projects in Stanton Springs for the prior year on or before March 15 of each year to each entity in accordance with the payout percentages as follows:
  1. Jasper County shall receive 10.0% with payment to be divided between Jasper County and the Jasper County School District per an Intergovernmental Agreement between Jasper County and the Jasper County School District dated October 4, 2021; and
  2. Morgan County shall receive 15.0% with payment to be divided between Morgan County and the Morgan County School District based upon their proportionate millage rates; and
  3. Newton County shall receive 37.5% with payment to be divided between Newton County and the Newton County School District based upon their proportionate millage rates; and
  4. Walton County shall receive 37.5% with payment to be divided between Walton County and the Walton County School District based upon their proportionate millage rates.

- h. The Authority shall distribute PILOT Payments received for projects in Stanton Springs North for the prior year on or before March 15 of each year to each entity in accordance with the payout percentages as follows:
  1. Social Circle shall receive 5% with payment to be divided between Social Circle and the Social Circle School District based upon their proportionate millage rates; and
  2. Walton County shall receive 35.625% with payment to be divided between Walton County and the Walton County School District based upon their proportionate millage rates.
  3. Newton County shall receive 35.625% with payment to be divided between Newton County and the Newton County School District based upon their proportionate millage rates; and
  4. Morgan County shall receive 14.25% with payment to be divided between Morgan County and the Morgan County School District based upon their proportionate millage rates;
  5. Jasper County shall receive 9.5% with payment to be divided between Jasper County and the Jasper County School District per an Intergovernmental Agreement between Jasper County and the Jasper County School District dated October 4, 2021.
- i. The Authority shall cause to be performed an annual independent audit of its finances. Said audit shall be included in the Authority's budgeted expenses which shall be paid using Other Revenues or Tax Revenues or PILOT Payments when necessary. A copy of the audit shall be distributed to all Counties, School Districts and the City.
- j. On or before February 15<sup>th</sup> of each year, the Authority shall prepare and submit to the state revenue commissioner and state auditor the report and information required pursuant to O.C.G.A. § 36-62-5.1(g)(1).

6.

#### **Counties' and City Obligations and Consent**

The Counties and City hereby agree as follows:

- a. The Collecting Commissioner shall collect and declare any and all Tax Revenues generated from real property and personal property lying on or in Stanton Springs or Stanton Springs North as applicable and shall supervise a separate accounting for said Tax Revenues so as to segregate said collections from other County or City tax revenues. As compensation for the Collecting Commissioner's duties hereunder, the Collecting Commissioner shall be entitled to a commission of 2.5% of any amounts otherwise payable by the Collecting Commissioner to any other County, City or School District.
- b. The Collecting Commissioners shall, before January 1 of each year, prepare a report of all Tax Revenues collected by said County and deliver a copy of said annual report to the Counties, City, School Districts, and the Authority.
- c. Between May 1 and May 31 each year, the Counties may submit to the Authority and the Counties a written objection to the Expenses stated in the Authority's operating budget for

July 1 through June 30 of the same year. Said objection shall specify the grounds for the objection. Pending resolution of the objection, the Collecting Commissioner shall remit Tax Revenues to the Authority in the amount of its operating budget approved for the prior year. No Tax Revenues may be distributed to the Counties, City or School Districts until the objection is resolved.

- d. If no objections are submitted, on or before May 31 of each year, the Collecting Commissioner shall remit Tax Revenues to the Authority in an amount sufficient to meet the Authority's annual budget requirements for the Authority's Expenses and Debt Service Obligations not otherwise budgeted to be paid by Other Revenues as established by the Authority's annual budget report. If more than one County or City collects Tax Revenues in a given year, each Collecting Commissioner shall pay a pro rata share of the Authority's budget based on that Government's share of the total taxes collected.
- e. The Collecting Commissioner shall determine Net Tax Revenues to be remitted to the Counties, City and School Districts by subtracting from Tax Revenues the funds paid to the Authority in accordance with subparagraph (d).
- f. The Collecting Commissioner shall remit Net Tax Revenues from Stanton Springs contemporaneously to each of the Tax Commissioners of the Counties for the previous tax year on or before March 15<sup>th</sup> as follows:
  - i. Jasper County and the Jasper County School District shall collectively receive 10.0% of the said Net Tax Revenues (2.5% of said amount shall be withheld as commissions for the Collecting Commissioner);
  - ii. Morgan County and the Morgan County School District shall collectively receive 15.0% of the said Net Tax (2.5% of said amounts shall be withheld as commissions for the Collecting Commissioner);
  - iii. Newton County and the Newton County School District shall collectively receive 37.5% of the said Net Tax Revenues (2.5% of said amounts shall be withheld as commissions for the Collecting Commissioner);
  - iv. Walton County and the Walton County School District shall collectively receive 37.5% of the said Net Tax Revenues (2.5% of said amounts shall be withheld as commissions for the Collecting Commissioner).
- g. The Collecting Commissioner shall remit Net Tax Revenues from Stanton Springs North contemporaneously to each of the Tax Commissioners of the Counties and the City Clerk of Social Circle for the previous tax year on or before March 15<sup>th</sup> as follows:
  - i. Jasper County shall receive 9.5 % of the said Net Tax Revenues (2.5% of said amount shall be withheld as commissions for the Collecting Commissioner);
  - ii. Morgan County and the Morgan County School District shall collectively receive 14.25 % of the said Net Tax Revenues (2.5% of said amounts shall be withheld as commissions for the Collecting Commissioner);
  - iii. Newton County and the Newton County School District shall collectively receive 35.625 % of the said Net Tax (2.5% of said amounts shall be withheld as commissions for the Collecting Commissioner);

- iv. Walton County and the Walton County School District shall collectively receive 35.625% of the said Net Tax Revenues (2.5% of said amounts shall be withheld as commissions for the Collecting Commissioner); and
- v. The City of Social and the City of Social Circle School District shall collectively receive 5% of the said Net Tax Revenues (2.5% of said amounts shall be withheld as commissions for the Collecting Commissioner).
- h. The Tax Commissioners for Morgan, Walton and Newton Counties shall distribute their portion of the Net Tax Revenues received from the Collecting Commissioner on or before March 31st of each year to their respective County and School Board based on the proportion of their millage rates.
- i. The Tax Commissioner for Jasper County shall distribute Jasper County's portion of the Net Tax Revenues received from the Collecting Commissioner on or before March 31st of each year with payments divided between Jasper County and the Jasper County School District pursuant to the Intergovernmental Agreement between Jasper County and Jasper County School District dated October 4, 2021.
- j. The Social Circle City Clerk shall distribute Social Circle's portion of the Net Tax Revenues received from the Collecting Commissioner on or before March 31<sup>st</sup> of each year to the City and the Social Circle School District based on the proportion of their millage rates.
- k. Other Revenues distributed to the Counties by the Authority may be used at the Counties' discretion.
- l. No later than January 1 of each year, Morgan, Newton and Walton County and the City of Social Circle shall provide to the Collecting Commissioner the percentage split of Net Tax Revenues between that County and that County's School District or the City and the City's School District as applicable, based on the proportion of the prior year's millage rate of that County or City to the millage rate of that County's School District. The Collecting Commissioner shall use such percentage to calculate the amount of Net Tax Revenues that the City of Social Circle, and Newton, Morgan and Walton Counties and their respective School Districts are to be paid.
- m. Any tax refunds due property owners in Stanton Springs or Stanton Springs North shall be paid by the Collecting Commissioner in the time period prescribed by law (O.C.G.A. § 48-5-380, 241). The Collecting Commissioner's County shall be reimbursed by the Counties, City and School Districts based on their pro rata share of the refund amount. The Collecting Commissioner shall invoice the Counties and School Districts.
- n. Should the Collecting Commissioner deem it in the best interest of the parties to conduct an external tax audit of real or personal property attributed to a tenant(s) in Stanton Springs or Stanton Springs North, said audit shall be paid for by the Counties, City, and School Districts based on their pro rata shares.
- o. The Counties and City shall adjust their tax digest to reflect the portion of Tax Revenues attributed to it from distributions from Stanton Springs and Stanton Springs North in accordance with O.C.G.A. § 36-62-5.1(g)(3).

7.

**Board of Tax Assessors Obligations**

**a. Point of Contact**

The Assessing BOA shall serve as the single point of contact with the Tenant as it relates to ad valorem property taxes.

**b. Assessment Process for: No Tax Abatement or Phase-In Lease Valuation Structure**

1. On or before April 1<sup>st</sup> of each year, the Chief Appraiser for Morgan, Newton and Walton BOA shall prepare and provide a spreadsheet consistent with the sample provided in attached Exhibit “C” to each BOA and the Authority with the following information for the current tax year regarding each Tenant Property (real and personal), including property owned by the Authority, that it is responsible for assessing:
  - a. Parcel number
  - b. Address
  - c. Owner name
  - d. Tenant name
  - e. Description
  - f. 100% fair market value
  - g. Assessed value
  - h. Note if it is a PILOT Structure
  - i. Note if it is subject to a Phase-In Lease Valuation Structure
  - j. Phase-in percentage (if a Phase-In Lease Valuation Structure)
  - k. Note whether it is Exempt or Taxable
  - l. Exempt value to be reported by each BOA based on their Payout Percentage
  - m. Taxable value to be reported by each BOA based on their Payout Percentage
2. Each BOA shall include the values applicable to its County/City shown on the spreadsheet with all other digest values to be approved by the BOA prior to mailing Assessment Notices.
3. Each BOA shall input the assessment value for the property into its system based on its Payout Percentage. For example, if the total assessed value of a parcel within the Stanton Springs were \$100,000, Jasper County would report \$10,000, Morgan County would report \$15,000, and Walton County and Newton County would each report \$37,500 on their respective Tax Digests. If the total assessed value of a parcel within Stanton Springs North were \$100,000, the City would report \$5,000, Jasper County would report \$9,500, Morgan County would report \$14,250, and Walton County and Newton County would each report \$35,625 on their respective Tax Digests.
4. Each BOA shall mail their Assessment Notice showing its portion of the total value of each Tenant Property to the Assessing BOA Chief Appraiser and Collecting Commissioner. If the BOA uses the Wingap software system, this would be achieved by listing the Assessing BOA Chief Appraiser as the primary recipient and the Collecting Commissioner as the agent recipient.

5. The Assessing BOA shall prepare and mail one Assessment Notice to the Tenant showing the sum of all the Counties' portion of the value such that the notice shows the 100% value. Once the single Assessment Notice has been printed and mailed, the Chief Appraiser shall correct the value in its system back to the Payout Percentage for its County.
6. Each BOA and the City shall submit their Tax Digest reporting their Payout Percentage of the assessed value of the Property per the requirements of House Bill 406.
7. Within five (5) days of approval of the Tax Digest, the Assessing BOA shall create a Digest correction by preparing an Error and Release or ACO report requesting the Digest be corrected to show the 100% value of the property and submit the same to the Collecting Commissioner.
8. Within one (1) day after submitting the Digest correction, the Assessing BOA shall reverse the Error and Release or ACO.

***c. Assessment Process for: Payment In Lieu of Taxes Structure***

During the PILOT period, each Tax Assessor shall report its portion of the assessed value of the Tenant Property subject to the PILOT on its exempt Digest in accordance with the spreadsheet provided by the Assessing BOA in Paragraph 7( b) (1) herein and by following the steps listed in Paragraph 7 (b) (2) – (8) above.

***d. Mapping/Parcel Identification***

1. Each BOA shall identify the Property by the parcel identification number first assigned by the Assessing BOA.
2. Each BOA shall remove the valuation of property in Stanton Springs and Stanton Springs North from its QPublic website. If the BOA uses the Wingap software system, this is achieved by going to the Payout screen and checking the non-disclosure box for the particular parcel.

8.

**Tax Commissioners Obligations**

***a. Digest Reporting***

All Tax Commissioners and the City shall report the value of the property in Stanton Springs and Stanton Springs North, as applicable, based on their Payout Percentage in their Tax Digest per House Bill 406.

***b. Annual Report of Taxes Collected***

On or before January 1 of each year, the Collecting Commissioner shall provide a report of the total taxes collected, the commission calculation and the amounts to be distributed to the Authority, the City, each County, and each School District as dictated herein.

***c. Process for: No Tax Abatement or Phase-In Lease Valuation Structure***

1. The Tax Commissioners and the City shall send bills for the Tenant Property based on their Payout Percentage to the Collecting Commissioner.
2. The Collecting Commissioner shall send one bill to the Tenant based on the 100% valuation of the Tenant Property as shown on the Error and Release or ACO report provided by the Assessing BOA.
3. The Collecting Commissioner shall receive payment from the Tenant and distribute it to the Authority, the City or the Tax Commissioners of Jasper, Morgan, Newton and Walton Counties as determined by the distributions due each herein. Distributions to the Tax Commissioner for Jasper, Morgan, Newton and Walton County and to the City of Social Circle shall include a letter referencing the proportion split obligations for payments to the Counties, City and School Boards. Each Tax Commissioner shall distribute the monies in accordance with Paragraph 6 herein.

***d. Process for: Payment In Lieu of Taxes Structure***

1. During the PILOT period, the Tax Commissioners shall not generate bills or collect payments. The Authority will handle billing, collection, and distribution of PILOT Payments.
2. After the PILOT Payment period, Tax Commissioners shall follow the Process for: No Tax Abatement stated above.

***e. Tax Commissioner and City Tax Payment Websites***

The Tax Commissioners and the City shall either remove online billing options for property in Stanton Springs and Stanton Springs North or include the following language in red, bold letters on the Property Tax Statement form: “Do not pay online. Value and taxes reflect \_\_\_\_\_ County’s/City’s \_\_\_% portion only. Contact Tax Commissioner/City for 100% value and taxes due.” The blanks shall be filled in with the name of the County/City and its Payout Percentage.

9.

**Authority Budget and Expenses**

- a. The parties understand and acknowledge the annual operating budgets prepared by the Authority are based on its estimate of reasonable and foreseeable expenses.

- b. In the event the Authority’s actual expenditures are less than budgeted expenditures, any excess Tax Revenues or PILOT Payments received shall be distributed in accordance with Paragraph 5(g). Notwithstanding the above, the Authority may keep a reasonable amount of budgeted reserve funds and capital project funds for multi-year projects.
- c. In the event the Authority’s actual expenditures exceed budgeted expenditures due to unforeseen circumstances, including but not limited to the location or expansion of a new business within Stanton Springs or Stanton Springs North or litigation, reimbursement of those expenses shall be included in the budget for the following fiscal year. Within thirty (30) days of the Authority becoming aware it will incur unbudgeted expenses, the Authority shall provide the Counties , City and School Districts with an estimate of the unbudgeted expenditure and an explanation of the circumstances giving rise to the expenditure.
- d. In the event the Authority’s annual operating budget exceeds the Other Revenues, PILOT Payments, and Tax Revenues levied and collected in any given year, the Authority shall fund the balance of its budgeted operating expenses as follows:
  - i. Provided the Authority has access to an existing, County-approved, line of credit with a financial institution, the Authority shall make draws from said line of credit to meet its budget requirements for that year. Repayment of funds drawn from the line of credit shall then be added to the Authority’s budgets for the following fiscal years until said funds, including any interest thereon, have been repaid in full; or
  - ii. If the Authority does not have access to an existing, County-approved line of credit, the Authority shall send invoices for the balance of its budgeted operating expenses to the Counties within thirty (30) days of the Authority’s receipt of its share of the Tax Revenues from the Collecting Commissioner or Counties. Said invoices shall reference each County’s share of the balance of the Authority’s budgeted operating expenses based on the agreed upon percentages as follows:
    - 1.Jasper County shall pay 10.0%;
    - 2.Morgan County shall pay 15.0%;
    - 3.Newton County shall pay 37.5%; and
    - 4.Walton County shall pay 37.5%.

10.

**School District Consent**

To the extent permitted by law, the City of Social Circle, Jasper County, Morgan County, Newton County and Walton County School Districts (“School Districts”) hereby expressly consent to the terms, provisions, agreements and requirements herein and waive any rights or claims to Tax Revenues and PILOT Payments other than those specifically referenced herein.



11.

**Tax Assessor Consent and Authorization to Contract**

To the extent permitted by law, the Jasper County, Morgan County, Newton County and Walton County Board of Tax Assessors hereby expressly consent to the terms, provisions, agreements and requirements stated herein. Each County hereby expressly authorizes its Board of Tax Assessors to enter into this agreement and future agreements with the Authority and companies locating within Stanton Springs or Stanton Springs North which are consistent herewith.

12.

**Tax Commissioner Consent**

To the extent permitted by law, the Jasper County, Morgan County, Newton County and Walton County Tax Commissioners hereby expressly consent to the terms, provisions, agreements and requirements stated herein.

13.

**Economic Development Negotiations**

In order to be competitive in the economic development marketplace, the Authority is hereby authorized to negotiate with prospective business and industrial purchasers or tenants for payments in lieu of ad valorem taxation or tax abatements consistent and in accordance with applicable law(s).

14.

**Centralized Inspection and Building-Permitting**

It is to the benefit of the parties that the development of Stanton Springs and Stanton Springs North occurs in a consistent manner. Therefore, the parties hereby agree the inspection and building-permit function for development within Stanton Springs and Stanton Springs North shall be handled by the planning and zoning department so designated by the Authority pursuant to the terms of the Intergovernmental Contract Re: Development Services for Stanton Springs dated March 2, 2021 and executed by Jasper, Morgan Newton and Walton Counties and the Authority, and the May 18, 2021 Intergovernmental Contract Re: Stanton Springs North between the City of Social Circle and the Authority. The planning and zoning department handling the building-permit function, if different from the County in which a project lies, shall provide the Assessing BOA a copy of each permit issued for purposes of tracking real property values.

15.

**General**

- a. Should any clause, sentence or paragraph herein contained be held invalid or unconstitutional, it shall in nowise affect the remaining provisions of this Contract, which shall otherwise remain in full force and effect.
- b. This Contract may be executed in several counterparts, each of which shall be an original but all of which shall constitute but one and the same instrument.
- c. This Contract shall be construed and enforced in accordance with the laws of the State of Georgia.
- d. This Contract supersedes and replaces the 2004 Contract and 2016 Contract rendering the 2004 Contract and 2016 Contract null and void.

16.

**Notices**

All notices, correspondence, payments, and other communications required under this Contract shall be delivered to:

<p><b>For the Authority:</b>  Chairman  300 E Church Street  Monroe, GA 30655  <u>With a copy to:</u>  Andrea P. Gray, Attorney at Law  P.O. Box 826  Monroe, Georgia 30655</p>	
<p><b>For Jasper County:</b>  Jasper County Board of Commissioners  Attn: Chair, Board of Commissioners  126 W. Green Street  Suite 18  Monticello, GA 31064  <u>With a copy to:</u>  David Ozburn  Ozburn Law Firm, LLC  1108 Monticello Street SW  Covington, Georgia 30014</p>	<p><b>For Jasper County School District:</b>  Chairman  1411 College Street  Monticello, Georgia 31064  <u>With a copy to:</u>  Cory Kirby  Harben, Hartley &amp; Hawkins, LLP  Wells Fargo Center, Suite 750  340 Jesse Jewell Parkway  Gainesville, Georgia 30501</p>
<p><b>Jasper County Board of Tax Assessors</b>  Chief Appraiser  126 W Greene St # 124,  Monticello, GA 31064</p>	<p><b>Jasper County Tax Commissioner</b>  Tax Commissioner  126 W. Green Street  Monticello, GA 31064</p>

<p><b>For Morgan County:</b>  Morgan County  Attn: County Manager  150 East Washington Street  Suite 100  Madison, GA 30650  <u>With a copy to:</u>  Christian G. Henry  440 College Avenue N, Suite 120  Athens, GA 30601</p>	<p><b>For Morgan County School District:</b>  Morgan County School System  1065 East Ave  Madison, GA 30650  <u>With a copy to:</u>  Cory Kirby  Harben, Hartley &amp; Hawkins, LLP  340 Jesse Jewell Parkway  Wells Fargo Center, Suite 750  Gainesville, GA 30501</p>
<p><b>Morgan County Board of Tax Assessors</b>  Chief Appraiser  150 E Washington St Ste 130  Madison, GA 30650</p>	<p><b>Morgan County Tax Commissioner</b>  Tax Commissioner  P.O. Box 151  Madison, GA 30650</p>
<p><b>For Newton County:</b>  Chairman of the Newton County Board of Commissioners  1124 Clark Street  Covington, GA 30014  <u>With a copy to:</u>  Aaron Meyer  County Attorney  Jarrard &amp; Davis, LLP  105 Pilgrim Village Drive, Suite 200  Cumming, GA 30040</p>	<p><b>For Newton County School District:</b>  Superintendent  NCBOE  2109 Newton Drive  Covington, GA 30014  <u>With a copy to:</u>  William A. White  Smith, Welch, Webb &amp; White, LLC  P.O. Box 10  2200 Keys Ferry Court  McDonough, Ga. 30253</p>
<p><b>Newton County Board of Tax Assessors</b>  Chief Appraiser  1113 Usher St NE # 102  Covington, GA 30014</p>	<p><b>Newton County Tax Commissioner</b>  Tax Commissioner  1113 Usher Street  Suite 101  Covington, GA 30014</p>
<p><b>For Walton County:</b>  Walton County Finance Department  303 S. Hammond Drive, Suite 333  Monroe, Georgia 30655  <u>With a copy to:</u>  Walton County Tax Commissioner  303 S. Hammond Drive, Suite 100  Monroe, Georgia 30655</p>	<p><b>For Walton County School District:</b>  Walton County School District  200 Double Springs Church Rd.  Monroe, GA 30656  Attention: Superintendent  <u>With a copy to:</u>  Michael C. Pruett  Hall Booth Smith, P.C.  440 College Ave., Suite 120  Athens, Georgia 30601</p>

<b>Walton County Board of Tax Assessors</b> Chief Appraiser 303 S Hammond Dr #109 Monroe, GA 30655	<b>Walton County Tax Commissioner</b> Tax Commissioner 303 S Hammond Dr. Suite 100 Monroe, GA 30655
<b>For Social Circle</b> Mayor c/o City of Social Circle PO Box 310 Social Circle, GA 30025	<b>For Social Circle School District:</b> 147 Alcova Drive Social Circle GA 30025

IN WITNESS WHEREOF, the parties, action by and through their duly authorized officers, have caused this Contract to be executed in multiple counterparts under seals as of the day and year first above written.

[Execution Page for AMENDED AND RESTATED INTERGOVERNMENTAL CONTRACT Re: REVENUE SHARING, made and entered into as of the \_\_\_ day of \_\_\_\_\_, 2021, by and between the City of Social Circle, Jasper County, Morgan County, Newton County, Walton County, Jasper County School District, Morgan County School District, Newton County School District, Walton County School District, City of Social Circle School District, Board of Tax Assessors of Newton, Walton, Morgan and Jasper Counties, Tax Commissioners of Jasper, Morgan, Newton and Walton Counties, and the Joint Development Authority of Jasper, Morgan, Newton, and Walton Counties]

JASPER COUNTY, GEORGIA

By: \_\_\_\_\_  
Chairman, Board of Commissioners  
of Jasper County

(SEAL)

Attest:

\_\_\_\_\_  
Clerk, Board of Commissioners  
of Jasper County

**RESOLUTION TO APPROVE THE  
AMENDED AND RESTATED INTERGOVERNMENTAL CONTRACT  
RE: REVENUE SHARING AGREEMENT FOR STANTON SPRINGS AND STANTON  
SPRINGS NORTH**

**WHEREAS**, on October 18, 2000, the Joint Development Authority of Jasper County, Morgan County, Newton County and Walton County ( the “Authority”) acquired an approximately 1,528-acre site which has been expanded to now total approximately 1,635 acres, which site is located in Morgan, Newton, and Walton Counties, in order to proceed with the development of a research park known as Stanton Springs; and

**WHEREAS**, by separate intergovernmental contracts dated October 1, 2000, the Counties agreed to make debt service payments on the Bonds based on the following percentages:

Jasper County	10.0%
Morgan County	15.0%
Newton County	37.5%
Walton County	37.5%;

**WHEREAS**, on May 27, 2021, the Authority acquired an approximately 665-acre site located north of Interstate 20 which lies in part in the Walton County, the City of Social Circle and Morgan County to proceed with the development of an industrial park known as Stanton Springs North; and

**WHEREAS**, On December 2, 2004, the Authority and the Counties entered into an Intergovernmental Contract (“2004 Contract”) which, among other things, specified the distribution of revenues, tax payments and payments in lieu of taxes collected on or in connection with the Stanton Springs; and

**WHEREAS**, On September 20, 2016, the Authority, Counties and School Districts entered into an Intergovernmental Contract (“2016 Contract”) which superseded the 2004 Contract and provided clarity on the procedures, rights, and obligations for sharing tax revenue and other revenues generated from Stanton Springs; and

**WHEREAS**, as a result of the implications of the 2016 Contract on the Counties’ tax digests, amendments to O.C.G.A. §36-62-5.1 and §48-5-274 were required and made by House Bill 406, to ensure the tax digests of the Counties accurately reflected each County’s portion of the property value in Stanton Springs and Stanton Springs North; and

**WHEREAS**, implementation of the 2016 Contract and House Bill 406 require close coordination and uniform procedures between the Boards of Tax Assessors and Tax Commissioners of each County and City which resulted in Procedure Manuals being independently adopted by the County Board of Tax Assessors and Tax Commissioners from each County in 2020; and

**WHEREAS**, on May 18, 2021, the Authority and Social Circle entered into an Intergovernmental Contract regarding Stanton Springs North underwhich the Authority agreed to initiate a revision of the 2016 Contract to account for tax revenue division for property in Stanton Springs North; and

**WHEREAS**, the Jasper County desires to amend the 2016 Contract to incorporate the addition of Stanton Springs North, the City of Social Circle and the Social Circle School District, account for the requirements of House Bill 406, and define the procedures, rights and obligations associated with sharing tax revenue and other revenues generated therein with all parties.

**NOW, THEREFORE, BE IT RESOLVED** by the Jasper County Board of Commissioners that the Amended and Restated Intergovernmental Contract Re. Revenue Sharing Agreement for Stanton Springs and Stanton Springs North, a draft of which is attached hereto as Exhibit "A" and incorporated herein by reference, is approved as to form subject to non-material revisions reviewed and approved by legal counsel, and the Chairman and Secretary are authorized to execute said Contract.

**SO RESOLVED** this \_\_\_\_ day of \_\_\_\_\_, 2021

Jasper County Board of Commissioners

By: \_\_\_\_\_  
Name:  
Title: Chairman

Attest: \_\_\_\_\_  
Name:  
Title: Secretary

(SEAL)

**Agenda Request – Jasper County BOC**

**Department:** Roads and Bridges

**Date:** November 1, 2021

**Subject:** 2022 LMIG Application Project Approval

**Summary:**

On Oct 4, 2021 the BOC approved the section of Jackson Lake Rd from SR 11 to SR 212 as the road project for the 2022 LMIG application. Engineering estimates were requested for options including resurfacing type, width and length.

Status

Jackson Lake Rd section from SR 11 North to SR 212 West

Section length - 4.1 Miles

Current Width – 20 Ft.

Engineering Cost Estimates Based on:

FDR and Overlay

Widen Existing Road from 20’ to 22’

Option 1

Length 2.36 Miles

Engineering Cost Estimate per Mile \$323,507

Total Engineering Cost Estimate \$763,477

Option 2

Length 4.1 Miles

Engineering Cost Estimate per Mile \$322,536

Total Engineering Cost Estimate \$1,322,398

Option 2 Requires Additional Funding of \$561,494 Over 2022 LMIG Minimum Project Cost

Other Resurfacing Options to be Discussed

**Background:**

GDOT 2022 LMIG Funding \$585,310.96

County Required 30% Match \$175,593.29

Total Project Minimum Cost \$760,904.25

**Cost:**

Final Cost Based on Project Road Length and Actual Bid Costs Received

Funding Sources for Additional Funding Required with Option 2 to be Discussed

**Recommended Motion:** Board Discretion



# Jasper County 2022 LMIG

## Engineer's Cost Estimate - Jackson Lake Rd north section - FDR and overlay

PROJECT NAME	Jackson Lake Rd - north	2.35 MILES existing 20' pavement width with widening to 22' total width
PROJECT LOCATION	Jasper County	
Estimate Date	10/22/21	
LMIG Grant Year	2022	

<u>Item No.</u>	<u>Description</u>	<u>Quantity</u>	<u>Unit</u>	<u>Unit Price</u>	<u>Amount</u>
1	Mobilization/Demob; project management; bonding; other misc items	1	LS	\$7,500.00	\$7,500.00
2	Traffic Control, signage, etc.	1	LS	\$15,000.00	\$15,000.00
3	Full-depth (10") reclamation of base	30331	SY	\$7.59	\$230,209.76
4	Portland cement (type 1 or 2) 59.5 lbs/sy (includes prime coat)	902	TN	\$183.00	\$165,127.73
5	Asphalt overlay: 12.5 mm SP recycled asphalt 2" thickness (220 lb/sy)	3336	TN	\$85.05	\$283,758.55
6	Grading Complete (build 2' shoulder)	4.70	LM	\$6,025.00	\$28,317.50
7	Temporary and permanent grassing	2.35	AC	\$3,100.00	\$7,285.00
8	Thermo Traffic Stripe 5 in white (edge)	4.70	LM	\$2,205.00	\$10,363.50
9	Thermo Traffic Stripe 5" yellow (dlb centerline)	2.35	LM	\$4,410.00	\$10,363.50
10	Thermo Stripe 24" (stop bar)	20	LF	\$15.75	\$315.00
11	Geotechnical testing and support	1	LS	\$2,000.00	\$2,000.00
<b>Total Project Cost</b>					<b>\$760,240.54</b>

cost per mile \$323,506.61

**20' to 22' widening; FDR, 2" overlay, striping, shoulders.**

# Jasper County 2022 LMIG

## Engineer's Cost Estimate - Jackson Lake Rd north section - FDR and overlay

PROJECT NAME	Jackson Lake Rd - north	4.1 MILES existing 20' pavement width with widening to 22' total width
PROJECT LOCATION	Jasper County	
Estimate Date	10/22/21	
LMIG Grant Year	2022	

<u>Item No.</u>	<u>Description</u>	<u>Quantity</u>	<u>Unit</u>	<u>Unit Price</u>	<u>Amount</u>
1	Mobilization/Demob; project management; bonding; other misc items	1	LS	\$10,000.00	\$10,000.00
2	Traffic Control, signage, etc.	1	LS	\$25,000.00	\$25,000.00
3	Full-depth (10") reclamation of base	52917	SY	\$7.59	\$401,642.56
4	Portland cement (type 1 or 2) 59.5 lbs/sy (includes prime coat)	1574	TN	\$183.00	\$288,095.19
5	Asphalt overlay: 12.5 mm SP recycled asphalt 2" thickness (220 lb/sy)	5821	TN	\$85.05	\$495,068.11
6	Grading Complete (build 2' shoulder)	8.20	LM	\$6,025.00	\$49,405.00
7	Temporary and permanent grassing	4.1	AC	\$3,100.00	\$12,710.00
8	Thermo Traffic Stripe 5 in white (edge)	8.20	LM	\$2,205.00	\$18,081.00
9	Thermo Traffic Stripe 5" yellow (dlb centerline)	4.10	LM	\$4,410.00	\$18,081.00
10	Thermo Stripe 24" (stop bar)	20	LF	\$15.75	\$315.00
11	Geotechnical testing and support	1	LS	\$4,000.00	\$4,000.00
<b>Total Project Cost</b>					<b>\$1,322,397.86</b>

cost per mile \$322,536.06

**20' to 22' widening; FDR, 2" overlay, striping, shoulders.**

**New Business – Item**

**Agenda Request – Jasper County BOC**

**Department:** Jasper County Fire Rescue

**Date:** November 1, 2021

**Subject:** Fire Rescue Department – Request for New Ambulance

**Summary:**

Jasper County Fire Rescue is seeking final approval for a purchase of a new ambulance.

**Background:**

Jasper County Fire Rescue was approved for a purchase of a new ambulance on 5-17-21 for \$180,000.00 funded by the Capital Expenditures Fund. Due to the COVID 19 Pandemic, lead times are greatly extended and available stock units are almost nonexistent. Jasper County Fire Rescue attended the EMS expo in Atlanta this past October and inquired with close to 20 vendors, with most vendors refusing to quote a new ambulance due the many unknowns such as ability to acquire new trucks, workforce problems, supply chain problems and increasing material costs extending lead times into 2023.

Capital Fund Approval on 5-17-21	\$180,000
Available Impact Fees Fire Allocation	<u>\$ 85,264</u>
Total	\$265,264

**Cost:**

**1. Custom Truck and Body Works**

- Demo – 2021 Chevy 4500 with new box – In stock estimated delivery 12/2021  
Price - \$ 236,505.00
- New Build – 2021 Ford 450 with new box – Estimated delivery 4/2022  
Price - \$ 193,053.00

**2. Ten 8 Fire**

- New Build – 2022 Ford 450 with new box – Estimated delivery 3/2022  
Price - \$ 237,041.00

**3. Specialty Vehicles**

- 2022 Ford F450 4\*4 with remounted box – Estimated delivery 03/2022  
Price – 205,800.00

**Recommended Motion:**

Board Discretion

INSTOCK DEMO

\$ 236,505

[cfinch@jaspercountyga.org](mailto:cfinch@jaspercountyga.org)

---

**From:** Jimmy Gill <jimmy@customtruckandbodyworks.com>  
**Sent:** Friday, October 22, 2021 1:02 PM  
**To:** CHRISTOPHER FINCH  
**Subject:** CUSTOM TRUCK AND BODY WORKS INC. - ATTACHED DEMO WITH LINE ITEM PRICING  
**Attachments:** JASPER COUNTY-ELITE-CTO - Type I CHEVY 4500 4X2-10-18-2021.pdf

Good afternoon,

I updated the quote to display the paint being line itemed. Let me know if you need anything else. Hopefully I will have some build time frames for you next week.

**Jimmy Gill – Sales Manager**  
**Custom Truck and Body Works, Inc.**  
M: 706-977-7095  
P: 706.553.9178  
F: 706.553.9179



**Custom Truck & Body Works, Inc.**

[www.customtruckandbodyworks.com](http://www.customtruckandbodyworks.com)





# JASPER COUNTY "ELITE SERIES 2021 DEMO"

VEHICLE & CHASSIS TYPE:		TYPE I 14' - CHEVROLET - 4500HD - 4x2 - DIESEL	
DATE PRICED OUT		10/22/2021	
		<b>VEHICLE TOTAL</b>	
		<b>\$234,355</b>	
PERFORMANCE BOND %		CTBW FEE (3%) =	\$0
<b>VEHICLE TOTAL (INCLUDING BOND IF APPLICABLE)</b>		<b>\$234,355</b>	
<b>OPTIONAL LINE ITEMS QUOTED (NOT INCLUDED IN TOTAL)</b>			
FEDERAL SIGNAL EQ2B PRICE: \$2,150.00			
DISMOUNT, REMOUNT, AND PAINT CAB/CHASSIS TO MATCH EXISTING FLEET PRICE: \$20,000.00			
<b>STANDARD BASE UPFIT CONVERSION w OPTION CHOICES</b>			
<b>CHASSIS ADD-ON / SECTION 1.0</b>			
Option - Suspension System - Liquid Springs			
Mud Flaps- DRW - No Logo			
Diamond Plate Running Boards - Reg Cab			
Spare Tire			
Option - Aluminum Wheels (ORDERED WITH CHASSIS)			
Option - GO INDUSTRIES BRUSH GUARD			
<b>MODULAR BODY / SECTION 2.0</b>			
All Aluminum Modular Body - Base 14' (MB/BC.E)			
Aluminium Thresholds Exterior Compartments			
Fenderette - Aluminum			
Flooring - Coosa Composite Sub Flooring ILO Wood			
Option - Insulation - Spray Foam			
Diamond Plate - All Compartments			
Splash Fill Guard: Polished Aluminum			
Window Curb Side Door - Sliding - Dark Tint - 18"X24" Ea			
Window Rear Door - Fixed - Dark Tint - 14"X24" Ea			

<b>PATIENT COMPARTMENT CABINET &amp; HARDWARE / SECTION 3.0</b>			
Cabinets - Option - (14') Painted Aluminum w Life Defender Restocking Windows			
Cabinet Over Rear Door			
Cabinet Over Squad Bench			
Countertops: (2) Solid Surface Staron	Select Color:		
Assist Handicap Entry Door Handles "V" Style			
Attendant Seat - Child 3 Point Safety with Swivel Base and Armrest -WISE	Select Color:		
Option - Cot Fastener System - Performance Load W Inductive Charger & Floor Plate - Stryker			
Cot Fastener System Position - Center			
Emergency Release Latch's on Entry Doors			
Fire Extinguisher #5 - Qty 2			
Flooring: Lonplate II - Gray- Rolled 3"			
Formica	Select Color:		
Glove Box Over Curbside Entry Door			
Grab Rails - Ceiling 72" - Yellow	Qty Needed:	2	
Harness - 6 Point	Qty Needed:	3	
Safety Grab Handle on Entry Doors - Yellow			
Safety Netting - Head Of Squad Bench			
Upholstery - Vacuum Formed	Select Color:		
<b>MEDICAL - OXYGEN EQUIPMENT - SECTION 4.0 &amp; 5.0</b>			
IV Hangers Recessed - Standard Is 2	Qty Needed:	2	
O2 Wrench Mounted			
Option - Oxygen Bracket - Zico Electric Lift			
Oxygen Outlets - Standard Is 3 - (2) Action Area (1) Head of Squad Bench	Qty Needed:	3	
Option - Rico Suction - Suction Aspirator - Recessed Below Action Area			
Vacuum Outlet - Standard Is 1	Qty Needed:	1	
Vacuum Pump			
<b>ENVIROMENTAL SYSTEMS / SECTION 6.0</b>			
Option - AC/Heat - Hoseline Brushless Motor *Ducted* System 12VDC-110V w T.M.C.			
Exhaust Fan/ Vent			
<b>ELECTRICAL / SECTION 7.0</b>			
Antenna Coax - Standard Is 2	Qty Needed:	2	
Additional Batteries	Qty Needed:	0	
Back Up Alarm			
Exterior Back Up Camera With 7" Monitor			
Clock - Digital EMS - Intellitec			
Option - Console - Aluminum	Select Color:	Black	
Electrical System - 12V Rctronics			
Power Panel Location - Interior - Standard			
Inverter Pre Wire			
Pre-Wire 12V Radio (2)			
Option - Power Locks - All Compartments & Entry Doors w Hidden Stealth Switch			
Shoreline: 20 Amp Auto Eject			
No Additional Siren			







## SUPPLEMENTAL PAINT LIMITED WARRANTY

### PAINT LIMITED WARRANTY:

Custom Truck & Body Works, Inc. (Custom Works) warrants to the original purchaser ("Owner") only that the paint applied by Custom Works to the exterior surface of the ambulance/rescue body shall be free from defects in materials and workmanship that materially impair the value of the motor vehicle under normal use, maintenance and service for a period of seven (7) years from the original delivery date or one hundred thousand (100,000) miles, whichever comes first. The warranty provides coverage for peeling or delaminating of the top coat and/or other layers of paint, cracking or checking, and loss of gloss caused by cracking, checking or hazing. All other items are excluded from coverage by this supplemental paint warranty. The warranty is pro-rated as follows: 0 - 24 months - 100%; 25 - 36 months - 75%; 37 - 48 months - 50%; 49 - 84 months - 25%

### WARRANTY REMEDY:

Owner's sole and exclusive remedy under this warranty shall be repainting of any areas upon which the paint was defective by an authorized Custom Works warranty facility. Owner shall bear all expenses arising out of or relating to transporting the product to the Custom Works facility. If Custom Works fails to repaint the defective portion within a reasonable time, then Custom Works shall be liable to the Owner for the reasonable costs of repainting by a third party without giving Custom Works at least 15 days prior written notice, during which time Custom Works may repaint the defective paint.

### WARRANTY REGISTRATION:

The Owner shall submit or cause the motor vehicle dealer to submit a "Custom Works Warranty Registration" form with 60 calendar days of the original delivery date. This warranty is not valid if the Custom Works Warranty Registration Form is not sent to Custom Works within 60 days after the date of purchase/delivery to the Owner.

### EXCLUSIONS:

The warranty does not cover

- Paint deterioration caused by blisters or other film degradation due to corrosion originating from the substrate.
- Hazing, chalking or loss of gloss caused by improper care, abrasive polishes, cleaning agents, heavy duty pressure washing, aggressive mechanical washing systems.
- Paint deterioration caused by abuse, accident, acid rain, chemical fall out or act of nature.
- Accidents, scratches, chips, bruises and/or gloss reduction due to normal use and maintenance.
- Custom finishes, exotic finishes or any finish other than standard finish procedures.
- Repairs done over previously refinished areas, unless stripped to bare metal or appropriate substrate.
- Normal wear and tear, abuse, accident, neglect, misuse and/or altered/modified units.
- Claims made without following procedures or without proper authorization.
- Items not specifically designed as covered items.
- The expense of transporting the product to and from an authorized service center for service and all expenses arising from or related to such transportation.
- Incidental expenses such as but not limited to loss of use, inconvenience, loss of time, vehicle rental, lodging or travel costs, etc.
- Failure of finishes containing less than 100% Axalta approved products.
- Failure of finishes performed by non Axalta Certified Refinish Technician. All Axalta certifications must be current to be acceptable hereunder.

### WARRANTY TERMINATION

This warranty shall be void and Custom Works shall be relieved from any and all obligations hereunder if:

- Owner misuses or neglects the motor vehicle or the components fail to provide reasonable and necessary maintenance, perform or has performed unauthorized alterations of the components.
- The motor vehicle is sold or any of the components are removed.
- The vehicle is remounted, unless the remount is performed by Custom Works.
- Owner fails to comply with the warranty registration requirements described above.

### CUSTOM WORKS RIGHTS

Custom Works reserves the unrestricted right to alter or replace the components and/or design of its products from time to time with notice. These changes will be made with no obligation to make corresponding changes to products previously manufactured.

### CLAIM PROCEDURES

All warranty service shall be performed at Custom Works factory or at an authorized service facility. Custom Works must authorize all warranty service in writing prior to performance. Written authorization instructing the Owner as to where and when to deliver the product for warranty service will be given with four (4) working days of receipt of notification of defect made in writing to Custom Works within 30 days of discovery of the defect and must be submitted before the warranty expires. Notice shall contain the following information:

- Owner's name and complete address.
- Owner's contact information during regular business hours.
- Vehicle Identification Number (VIN)
- Unit model and Product Number.
- Date of purchase and delivery.
- Brief description of the problem and current odometer reading.
- Photographs are needed if the claim concerns any paint or body damage.

### DISCLAIMER LIMITATIONS

THIS WARRANTY IS IN LIEU OF ALL OTHER WARRANTIES EXPRESSED OR IMPLIED. INCLUDING BUT NOT LIMITED TO THE IMPLIED WARRANTIES OF MERCHANTABILITY AND FITNESS FOR ANY PARTICULAR PURPOSE. NOTE: APPLIES ONLY TO THE GENERAL ONE YEAR LIMITED WARRANTY AND NOT ANY OTHER OR EXTENDED WARRANTY OR WARRANTIES MADE BY CUSTOM WORKS. CUSTOM WORKS SHALL NOT BE LIABLE TO THE OWNER OR ANYONE ELSE FOR CONSEQUENTIAL, INCIDENTAL, SPECIAL, EXEMPLARY, INDIRECT, OR PUNITIVE DAMAGES ARISING FROM ANY DEFECT, DELAY, NON-DELIVERY, RECALL, OR OTHER BREACH BY CUSTOM WORKS INCLUDING BUT NOT LIMITED TO PERSONAL INJURY, DEATH, PROPERTY DAMAGE, LOST PROFITS OR OTHER ECONOMIC INJURY. CUSTOM WORKS SHALL NOT BE LIABLE TO THE OWNER OR ANYONE ELSE IN TORT FOR ANY NEGLIGENT DESIGN OR MANUFACTURE OR ANY PRODUCTS OR FOR THE OMISSION OF ANY WARNING WITH RESPECT THERETO.

### ADDITIONAL TERMS

This warranty provides Owner with specific rights and Owner may also have additional rights that vary from state to state. No other party may modify or expand the warranty provided herein, waive any of its limitations or make any different or additional warranties with respect to the products. Any statements to the contrary are hereby rendered null and void unless made in writing signed by an authorized officer of Custom Works

CUSTOM TRUCK & BODY WORKS, INC.  
13787 WHITE HOUSE ROAD  
WOODBURY, GA 30293  
888-258-9695

## SUPPLEMENTAL ELECTRICAL LIMITED WARRANTY

### ELECTRICAL LIMITED WARRANTY:

Custom Truck & Body Works, Inc. (Custom Works) warrants to the original purchaser ("Owner") only that the following items of the ambulance/rescue electrical system of the vehicle shall be free from substantial defects in materials and workmanship attributable to Custom Works ("Warrantor") that materially impair the value of the motor vehicle under normal use, maintenance and service for a period of seven (7) years from the original delivery date or sixty thousand (60,000) miles, whichever comes first for the electrical harness, harness installation and related components. All other components are excluded from the coverage of this limited electrical warranty.

### WARRANTY REMEDY:

Owner's sole and exclusive remedy under this warranty shall be repair or replacement (at Custom Work's sole option) the defective component by an authorized Custom Work's warranty facility. Owner shall bear all expenses arising out of or relating to transportation of the product to the appropriate warranty service location designated by Custom Works. If Custom Works or its authorized service facility fails to repair or replace any defective component within a reasonable time, then Custom Works shall be liable for the lesser of (i) the reasonable cost of repair or replacement by a third party or (ii) that part of the purchase price of the component that shall have been paid by the Owner to Custom Works, but the Owner shall not obtain repair or replacement by a third party without giving Custom Works at least 15 days prior written notice during which time Custom Works (or its authorized service facility) may repair or replace the defective product.

### WARRANTY REGISTRATION:

The Owner shall submit or cause the motor vehicle dealer to submit a "Custom Works Warranty Registration" form with 60 calendar days of the original delivery date. This warranty is not valid if the Custom Works Warranty Registration Form is not sent to Custom Works within 60 days after the date of purchase/delivery to the Owner.

### EXCLUSIONS:

The warranty does not cover

- Non-electrical components.
- Chassis electrical system and related components installed by the chassis manufacturer.
- Materials or parts not manufactured by Custom Works, including but not limited to batteries, battery chargers, inverters, lightbars, siren and similar equipment, tires, tire balancing, wheel alignment, light bulbs, generator(s), air conditioner(s), radios and power converters. The manufacturers of these products may provide warranties covering performance of their particular products.
- Normal wear and tear.
- Damage caused by overloading, abuse, accident, neglect or misuse.
- Components added or modified by third parties.
- Replacement of routine maintenance items.
- Damage caused by, but not limited to, collision, fire, theft or acts of God.
- Items not specifically designed as covered items.
- The expense of transporting the product to and from an authorized service center for service and all expenses arising from or related to such transportation.
- Incidental expenses such as but not limited to loss of use, inconvenience, loss of time, vehicle rental, lodging or travel costs, etc.

### WARRANTY TERMINATION

This warranty shall be void and Custom Works shall be relieved from any and all obligations hereunder if:

- Owner misuses or neglects the motor vehicle or the components fail to provide reasonable and necessary maintenance, perform or has performed unauthorized alterations of the components.
- The motor vehicle is sold or any of the components are removed.
- The vehicle is remounted, unless the remount is performed by Custom Works.
- Owner fails to comply with the warranty registration requirements described above.

### CUSTOM WORKS RIGHTS

Custom Works reserves the unrestricted right to alter or replace the components and/or design of its products from time to time with notice. These changes will be made with no obligation to make corresponding changes to products previously manufactured.

### CLAIM PROCEDURES

All warranty service shall be performed at Custom Works factory or at an authorized service facility. Custom Works must authorize all warranty service in writing prior to performance. Written authorization instructing the Owner as to where and when to deliver the product for warranty service will be given with four (4) working days of receipt of notification of defect made in writing to Custom Works within 30 days of discovery of the defect and must be submitted before the warranty expires. Notice shall contain the following information:

- Owner's name and complete address.
- Owner's contact information during regular business hours.
- Vehicle Identification Number (VIN)
- Unit model and Product Number.
- Date of purchase and delivery.
- Brief description of the problem and current odometer reading.
- Photographs are needed if the claim concerns any paint or body damage.

### DISCLAIMER LIMITATIONS

THIS WARRANTY IS IN LIEU OF ALL OTHER WARRANTIES EXPRESSED OR IMPLIED, INCLUDING BUT NOT LIMITED TO THE IMPLIED WARRANTIES OF MERCHANTABILITY AND FITNESS FOR ANY PARTICULAR PURPOSE. NOTE: APPLIES ONLY TO THE GENERAL ONE YEAR LIMITED WARRANTY AND NOT ANY OTHER OR EXTENDED WARRANTY OR WARRANTIES MADE BY CUSTOM WORKS. CUSTOM WORKS SHALL NOT BE LIABLE TO THE OWNER OR ANYONE ELSE FOR CONSEQUENTIAL, INCIDENTAL, SPECIAL, EXEMPLARY, INDIRECT, OR PUNITIVE DAMAGES ARISING FROM ANY DEFECT, DELAY, NON-DELIVERY, RECALL, OR OTHER BREACH BY CUSTOM WORKS INCLUDING BUT NOT LIMITED TO PERSONAL INJURY, DEATH, PROPERTY DAMAGE, LOST PROFITS OR OTHER ECONOMIC INJURY. CUSTOM WORKS SHALL NOT BE LIABLE TO THE OWNER OR ANYONE ELSE IN TORT FOR ANY NEGLIGENT DESIGN OR MANUFACTURE OR ANY PRODUCTS OR FOR THE OMISSION OF ANY WARNING WITH RESPECT THERETO.

### ADDITIONAL TERMS

This warranty provides Owner with specific rights and Owner may also have additional rights that vary from state to state. No other party may modify or expand the warranty provided herein, waive any of its limitations or make any different or additional warranties with respect to the products. Any statements to the contrary are hereby rendered null and void unless made in writing signed by an authorized officer of Custom Works

CUSTOM TRUCK & BODY WORKS, INC.  
13787 WHITE HOUSE ROAD  
WOODBURY, GA 30283  
888-258-9695

## SUPPLEMENTAL TWENTY YEAR STRUCTURAL LIMITED WARRANTY

### STRUCTURAL BODY LIMITED WARRANTY:

Custom Truck & Body Works, Inc. (Custom Works) warrants to the original purchaser ("Owner") only that each new aluminum body is structurally sound and free of all defects of both material and workmanship and further warrants that it will maintain such structural integrity and remain free of damage due to rusting for twenty (20) years from the original delivery date.

### WARRANTY REMEDY:

Owner's sole and exclusive remedy under this warranty shall be repair or replacement (at Custom Work's sole option) the defective component by an authorized Custom Work's warranty facility. Owner shall bear all expenses arising out of or relating to transportation of the product to the appropriate warranty service location designated by Custom Works. If Custom Works or its authorized service facility fails to repair or replace any defective component within a reasonable time, then Custom Works shall be liable for the lesser of (i) the reasonable cost of repair or replacement by a third party or (ii) that part of the purchase price of the component that shall have been paid by the Owner to Custom Works, but the Owner shall not obtain repair or replacement by a third party without giving Custom Works at least 15 days prior written notice during which time Custom Works (or its authorized service facility) may repair or replace the defective product.

### WARRANTY REGISTRATION:

The Owner shall submit or cause the motor vehicle dealer to submit a "Custom Works Warranty Registration" form with 60 calendar days of the original delivery date. This warranty is not valid if the Custom Works Warranty Registration Form is not sent to Custom Works within 60 days after the date of purchase/delivery to the Owner.

### EXCLUSIONS:

The warranty does not cover

- Materials or parts not manufactured by Custom Works, including but not limited to sealant, fasteners or other attachments and accessories.
- Normal wear and tear.
- Damage caused by improper loading, overloading, abuse, neglect or misuse.
- Components added or modified by third parties.
- Damage caused by, but not limited to, collision, fire, theft, vandalism or acts of God.
- Items not specifically designed as covered items.
- The expense of transporting the product to and from an authorized service center for service and all expenses arising from or related to such transportation.
- Incidental expenses such as but not limited to loss of use, inconvenience, loss of time, vehicle rental, lodging or travel costs, etc.

### WARRANTY TERMINATION

This warranty shall be void and Custom Works shall be relieved from any and all obligations hereunder if:

- Owner misuses or neglects the motor vehicle or the components fail to provide reasonable and necessary maintenance, perform or has performed unauthorized alterations of the components.
- The motor vehicle is sold or any of the components are removed.
- The vehicle is remounted, unless the remount is performed by Custom Works.
- Owner fails to comply with the warranty registration requirements described above.

### CUSTOM WORKS RIGHTS

Custom Works reserves the unrestricted right to alter or replace the components and/or design of its products from time to time with notice. These changes will be made with no obligation to make corresponding changes to products previously manufactured.

### CLAIM PROCEDURES

All warranty service shall be performed at Custom Works factory or at an authorized service facility. Custom Works must authorize all warranty service in writing prior to performance. Written authorization instructing the Owner as to where and when to deliver the product for warranty service will be given with four (4) working days of receipt of notification of defect made in writing to Custom Works within 30 days of discovery of the defect and must be submitted before the warranty expires. Notice shall contain the following information:

- Owner's name and complete address.
- Owner's contact information during regular business hours.
- Vehicle Identification Number (VIN)
- Unit model and Product Number.
- Date of purchase and delivery.
- Brief description of the problem and current odometer reading.
- Photographs are needed if the claim concerns any paint or body damage.

### DISCLAIMER LIMITATIONS

THIS WARRANTY IS IN LIEU OF ALL OTHER WARRANTIES EXPRESSED OR IMPLIED, INCLUDING BUT NOT LIMITED TO THE IMPLIED WARRANTIES OF MERCHANTABILITY AND FITNESS FOR ANY PARTICULAR PURPOSE. NOTE: APPLIES ONLY TO THE GENERAL ONE YEAR LIMITED WARRANTY AND NOT ANY OTHER OR EXTENDED WARRANTY OR WARRANTIES MADE BY CUSTOM WORKS. CUSTOM WORKS SHALL NOT BE LIABLE TO THE OWNER OR ANYONE ELSE FOR CONSEQUENTIAL, INCIDENTAL, SPECIAL, EXEMPLARY, INDIRECT, OR PUNITIVE DAMAGES ARISING FROM ANY DEFECT, DELAY, NON-DELIVERY, RECALL, OR OTHER BREACH BY CUSTOM WORKS INCLUDING BUT NOT LIMITED TO PERSONAL INJURY, DEATH, PROPERTY DAMAGE, LOST PROFITS OR OTHER ECONOMIC INJURY. CUSTOM WORKS SHALL NOT BE LIABLE TO THE OWNER OR ANYONE ELSE IN TORT FOR ANY NEGLIGENT DESIGN OR MANUFACTURE OR ANY PRODUCTS OR FOR THE OMISSION OF ANY WARNING WITH RESPECT THERETO.

### ADDITIONAL TERMS

This warranty provides Owner with specific rights and Owner may also have additional rights that vary from state to state. No other party may modify or expand the warranty provided herein, waive any of its limitations or make any different or additional warranties with respect to the products. Any statements to the contrary are hereby rendered null and void unless made in writing signed by an authorized officer of Custom Works

CUSTOM TRUCK & BODY WORKS, INC.  
13787 WHITE HOUSE ROAD  
WOODBURY, GA 30293  
888-258-9695

## SUPPLEMENTAL CONVERSION LIMITED WARRANTY

### CONVERSION LIMITED WARRANTY:

Custom Truck & Body Works, Inc. (Custom Works) warrants to the original purchaser ("Owner") only that the conversion components of the vehicle shall be free from substantial defects in materials and workmanship attributable to Custom Works ("Warrantor") that materially impair the value of the vehicle which arise under normal use, maintenance and service for a period of four (4) years from the original delivery date or forty-eight thousand (48,000) miles, whichever comes first.

### WARRANTY REMEDY:

Owner's sole and exclusive remedy under this warranty shall be repair or replacement (at Custom Work's sole option) the defective component by an authorized Custom Work's warranty facility. Owner shall bear all expenses arising out of or relating to transportation of the product to the appropriate warranty service location designated by Custom Works. If Custom Works or its authorized service facility fails to repair or replace any defective component within a reasonable time, then Custom Works shall be liable for the lesser of (i) the reasonable cost of repair or replacement by a third party or (ii) that part of the purchase price of the component that shall have been paid by the Owner to Custom Works, but the Owner shall not obtain repair or replacement by a third party without giving Custom Works at least 15 days prior written notice during which time Custom Works (or its authorized service facility) may repair or replace the defective product.

### WARRANTY REGISTRATION:

The Owner shall submit or cause the motor vehicle dealer to submit a "Custom Works Warranty Registration" form with 60 calendar days of the original delivery date. This warranty is not valid if the Custom Works Warranty Registration Form is not sent to Custom Works within 60 days after the date of purchase/delivery to the Owner.

### EXCLUSIONS:

The warranty does not cover

- Damage to the solid trim and detail items due to normal use, wear and tear or exposure to the elements
- Accessories or parts not manufactured by Custom Works, which include but is not limited to: the chassis and its component parts, tires, tire balancing, wheel alignment, inverters, sirens, light bulbs, lightbars, battery chargers, generators, radios, power converters and batteries. The manufacturers of these products may provide warranty covering the performance of their particular products.
- Normal wear and tear.
- Damage caused by overloading, abuse, accident, neglect or misuse.
- Components added or modified by third parties.
- Replacement of routine maintenance items.
- Damage caused by, but not limited to, collision, fire, theft or acts of God.
- Items not specifically designed as covered items.
- The expense of transporting the product to and from an authorized service center for service and all expenses arising from or related to such transportation.
- Incidental expenses such as but not limited to loss of use, inconvenience, loss of time, vehicle rental, lodging or travel costs, etc.

### WARRANTY TERMINATION

This warranty shall be void and Custom Works shall be relieved from any and all obligations hereunder if:

- Owner misuses or neglects the motor vehicle or the components fail to provide reasonable and necessary maintenance, perform or has performed unauthorized alterations of the components.
- The motor vehicle is sold or any of the components are removed.
- Owner fails to comply with the warranty registration requirements described above.

### CUSTOM WORKS RIGHTS

Custom Works reserves the unrestricted right to alter or replace the components and/or design of its products from time to time with notice. These changes will be made with no obligation to make corresponding changes to products previously manufactured.

### CLAIM PROCEDURES

All warranty service shall be performed at Custom Works factory or at an authorized service facility. Custom Works must authorize all warranty service in writing prior to performance. Written authorization instructing the Owner as to where and when to deliver the product for warranty service will be given with four (4) working days of receipt of notification of defect made in writing to Custom Works within 30 days of discovery of the defect and must be submitted before the warranty expires. Notice shall contain the following information:

- Owner's name and complete address.
- Owner's contact information during regular business hours.
- Vehicle Identification Number (VIN)
- Unit model and Product Number.
- Date of purchase and delivery.
- Brief description of the problem and current odometer reading.
- Photographs are needed if the claim concerns any paint or body damage.

### DISCLAIMER LIMITATIONS

THIS WARRANTY IS IN LIEU OF ALL OTHER WARRANTIES EXPRESSED OR IMPLIED, INCLUDING BUT NOT LIMITED TO THE IMPLIED WARRANTIES OF MERCHANTABILITY AND FITNESS FOR ANY PARTICULAR PURPOSE. NOTE: APPLIES ONLY TO THE GENERAL ONE YEAR LIMITED WARRANTY AND NOT ANY OTHER OR EXTENDED WARRANTY OR WARRANTIES MADE BY CUSTOM WORKS. CUSTOM WORKS SHALL NOT BE LIABLE TO THE OWNER OR ANYONE ELSE FOR CONSEQUENTIAL, INCIDENTAL, SPECIAL, EXEMPLARY, INDIRECT, OR PUNITIVE DAMAGES ARISING FROM ANY DEFECT, DELAY, NON-DELIVERY, RECALL, OR OTHER BREACH BY CUSTOM WORKS INCLUDING BUT NOT LIMITED TO PERSONAL INJURY, DEATH, PROPERTY DAMAGE, LOST PROFITS OR OTHER ECONOMIC INJURY. CUSTOM WORKS SHALL NOT BE LIABLE TO THE OWNER OR ANYONE ELSE IN TORT FOR ANY NEGLIGENT DESIGN OR MANUFACTURE OR ANY PRODUCTS OR FOR THE OMISSION OF ANY WARNING WITH RESPECT THERETO.

### ADDITIONAL TERMS

This warranty provides Owner with specific rights and Owner may also have additional rights that vary from state to state. No other party may modify or expand the warranty provided herein, waive any of its limitations or make any different or additional warranties with respect to the products. Any statements to the contrary are hereby rendered null and void unless made in writing signed by an authorized officer of Custom Works

CUSTOM TRUCK & BODY WORKS, INC.  
13787 WHITE HOUSE ROAD  
WOODBURY, GA 30293  
888-258-9695



NEW BOX

2021 FORD

MARCH/APRIL  
2022

[cfinch@jaspercountyga.org](mailto:cfinch@jaspercountyga.org)

---

**From:** Jimmy Gill <jimmy@customtruckandbodyworks.com>  
**Sent:** Monday, October 25, 2021 2:58 PM  
**To:** CHRISTOPHER FINCH  
**Subject:** CUSTOM TRUCK AND BODY WORKS INC. - F-450 TYPE I AMBULANCE INFORMATION

Good after noon Chief,

I hope you are having a good day. Per our conversation. If we choose to go with the chassis my dealer in Griffin has in stock we can start cutting metal for a new unit by years end and deliver the completed unit around March-April 2022. The chassis is a white 2021 Ford F-450 4x2 Diesel. We will have to repaint the chassis to red which will be an additional \$4,000.00. Let me know how you would like to proceed.

**Jimmy Gill – Sales Manager**  
**Custom Truck and Body Works, Inc.**  
M: 706-977-7095  
P: 706.553.9178  
F: 706.553.9179



**Custom Truck & Body Works, Inc.**

[www.customtruckandbodyworks.com](http://www.customtruckandbodyworks.com)



**From:** Jimmy Gill <jimmy@customtruckandbodyworks.com>  
**Sent:** Monday, August 9, 2021 9:00 AM  
**To:** CHRISTOPHER FINCH  
**Subject:** CUSTOM TRUCK AND BODY WORKS INC. - QUOTATION ATTACHED  
**Attachments:** Supplemental Body Limited Warranty.pdf; Supplemental Conversion Limited Warranty.pdf; Supplemental Electrical Sysytem Warranty.pdf; Supplemental Paint Limited Warranty.pdf; JASPER COUNTY FIRE-RESCUE-FORD F450 4X2-4X4 OPTION-CTO - Type I-8-4-2021.pdf

Good morning sir,

I hope you had a good weekend. I attached the warranties and the quote for the Ford 4x4 and 4x2 options with the requested line items. Dodge will not give me any pricing as they have not figured out the discount incentives (I have been waiting on Dodge for over a month now to get this figured out). Ford sent me this message in the email with your quote "NOTE: Keep in mind that we expect the 2022 model to balance out at any moment now. With that be prepared for a significant price increase for the next model year. This is based on being told that the "discounts" are likely to change considerably going forward for the foreseeable future." The order bank likely closed Friday or will be this week (this is new information as of Friday). I have no clue on what the 2023 prices will be and likely it will be a month or longer before I do. The lead times on Ford chassis are they plan on building the newest ordered units next May. I have a white one on my lot that would have to repainted, this would cost an additional \$4,000.00 to the quoted amount and the lead time would be May-June on this unit. If we were able to order one from Ford we would probably have a delivery of a finished unit of August-September. Let me know if you need any clarifications or have any questions. Thank you sir.

**Jimmy Gill – Sales Manager**  
**Custom Truck and Body Works, Inc.**  
M: 706-977-7095  
P: 706.553.9178  
F: 706.553.9179



**Custom Truck & Body Works, Inc.**

[www.customtruckandbodyworks.com](http://www.customtruckandbodyworks.com)



169 Box \$ 193,053



# JASPER COUNTY FIRE/RESCUE

<b>VEHICLE &amp; CHASSIS TYPE:</b>		<b>TYPE I 14' - FORD - F450 - 4x2 - DIESEL</b>
<b>DATE PRICED OUT</b>		<b>8/9/2021</b>
<b>VEHICLE TOTAL</b>		<b>\$186,903</b>
<b>PERFORMANCE BOND %</b>	<b>CTBW FEE (3%) =</b>	<b>\$0</b>
<b>VEHICLE TOTAL (INCLUDING BOND IF APPLICABLE)</b>		<b>\$186,903</b>
<b>OPTIONAL LINE ITEMS QUOTED (NOT INCLUDED IN TOTAL)</b>		
4X4 OPTION ADD: \$3,740.00		
FEDERAL SIGNAL EQ2B PRICE: \$2,150.00		
SPRAY FOAM INSULATION PRICE: \$2,625.00		
<i>ADD 4,000</i>		
<i>PAINT</i>		
<b>STANDARD BASE UPFIT CONVERSION w OPTION CHOICES</b>		
<b>CHASSIS ADD-ON / SECTION 1.0</b>		
Option - Suspension System - Liquid Springs		
Mud Flaps- DRW - No Logo		
Diamond Plate Running Boards - Reg Cab		
Spare Tire		
Option - Aluminum Wheels		
Option - Ranch Hand Legend Series Grill Guard		
<b>MODULAR BODY / SECTION 2.0</b>		
All Aluminum Modular Body - Base 14' (MB/BC.E)		
Aluminium Thresholds Exterior Compartments		
Fenderette - Aluminum		
Flooring - Coosa Composite Sub Flooring ILO Wood		
Insulation - Poly Fiber		
Scorpion Finish - All Compartments		
Splash Fill Guard: Polished Aluminum		
Window Curb Side Door - Sliding - Dark Tint - 18"X24" Ea		
Window Rear Door - Fixed - Dark Tint - 14"X24" Ea		



<b>PATIENT COMPARTMENT CABINET &amp; HARDWARE / SECTION 3.0</b>			
Option - Cabinets - (14') 3/4 Inch Plywood w Life Defender Restocking Windows			
Cabinet Over Rear Door			
Cabinet Over Squad Bench			
Countertops: (2) Solid Surface Staron	Select Color:		
Assist Handicap Entry Door Handles "V" Style			
Option - Attendant Seat - Child 3 Point Safety with Box Base - Wise	Select Color:	Gun Metal Gray	
Option - Cot Fastener System - Performance Load W Inductive Charger & Floor Plate - Stryker			
Cot Fastener System Position - Center			
Emergency Release Latch's on Entry Doors			
Fire Extinguisher #5 - Qty 2			
Flooring: Lonplate II - Gray- Rolled 3"			
Formica	Select Color:	Ash Gray - Matte	
Glove Box Over Curbside Entry Door			
Grab Rails - Ceiling 72" - Yellow	Qty Needed:	2	
Harness - 6 Point	Qty Needed:	4	
Safety Grab Handle on Entry Doors - Yellow			
Safety Netting - Head Of Squad Bench			
Upholstery - Vacuum Formed	Select Color:	Gun Metal Gray	
<b>MEDICAL - OXYGEN EQUIPMENT - SECTION 4.0 &amp; 5.0</b>			
IV Hangers Recessed - Standard Is 2	Qty Needed:	2	
O2 Wrench Mounted			
Oxygen Bracket - Universal Cylinder			
Oxygen Outlets - Standard Is 3 - (2) Action Area (1) Head of Squad Bench	Qty Needed:	4	
Rico Suction - Suction Aspirator - Located in Action Area			
Vacuum Outlet - Standard Is 1	Qty Needed:	1	
Vacuum Pump			
<b>ENVIROMENTAL SYSTEMS / SECTION 6.0</b>			
Option - AC/Heat - Hoseline Brushless Motor *Ducted* System 12VDC W T.M.C.			
Exhaust Fan/ Vent			
<b>ELECTRICAL / SECTION 7.0</b>			
Antenna Coax - Standard Is 2	Qty Needed:	2	
Additional Batteries	Qty Needed:	0	
Back Up Alarm			
Option - OEM Backup Camera			
Clock - Digital EMS - Intellitec			
Console - Wood - Scorpion	Select Color:	Black	
Electrical System - 12V Rctronics			
Power Panel Location - Interior - Standard			
Option - Inverter - Vanner 1050 Watt			
Inverter Pre Wire			
Pre-Wire 12V Radio (2)			
Option - Power Locks - All Compartments & Entry Doors w Hidden Stealth Switch			
Option - Shoreline 30 Amp Auto Eject			

Siren Standard- 295SLSA1		
No Additional Siren		
No Additional Siren		
Siren Speakers - Recessed Front Bumper Cast		
Timer - 15 Minute Check Out		
12V Outlets - Standard Is 3 - Loc: (1) AA - (1) TEL	Qty Needed:	3
110V GFI Duplex Outlets Lighted - Standard Is 3 - Loc: (1) AA - (1) TEL - (1) ALS	Qty Needed:	4
USB Outlets - Standard Is 2 - Loc: (1) AA - (1) Console	Qty Needed:	2
Wire Engine Block Heater - Shorline Supplied & Switched		
<b>LIGHTING (EMERGENCY) / SECTION 8.0</b>		
Whelen ION LED W/Bezels - Grille (2) Lights w Clear Lens - R/R		
Whelen ION LED W/Flanges - Front Intersection (2) Lights w Clear Lens - R/R		
Option - Whelen 900 Front Wall Straight- (7) Lights w/ Clear Lens R/R/R/C/R/R/R		
Option - Whelen 900 LED W/Flanges - Rear Wall (3) Lights w Clear Lens - R/A/R		
Option - Whelen 900 LED W/Flanges - Rear Window Level (2) w Clear Lens - R/R		
Option - Whelen 900 LED W/Flanges - Side (4) Lights w Clear Lens - R/R/R/R		
<b>LIGHTING (NON-EMERGENCY) / SECTION 8.0</b>		
Action Area - Standard Is 2	Qty Needed:	2
Compartment Light - Single Six (6) Led Strip Light		
Dome Lights - Whelen LED		
ICC Marker Lights - LED		
Option - Scene Lights: (6) Whelen 900 LED W/Flanges		
Spotlight: Handheld	Installed On Console	
Stepwell Light LED		
Option - S-T-T Lights - Whelen 600 / Arrow Turn / Led Reverse / Docking Lights		
Tag Light - LED		
<b>DECALS - GRAPHICS - LETTERING / SECTION 9.0</b>		
Option - One Color Body & OEM Color Chassis (Standard)		
Lettering & Graphics		
SOL Decals		
All Modular Door Panels - Chevrons		
<b>ADJUSTMENTS TO STANDARD:</b>		
(4) WHELEN ION GRILLE LIGHTS X PATTERN RED AND WHITE		
(3) WHELEN 700'S ON THE FRONT MOUNT CONDENSER		
(2) WHELEN 700'S ON THE SIDE OF THE CONDENSER (1 PER SIDE)		
ALS UPPER AND LOWER SECTION ONLY (NO DRAWER) 110V AND 12V IN LOWER SECTION		
3/4 HEIGHT L3 WITH STAIR CHAIR BRACKET (INSIDE ACCESS ONLY)		
L1 COMPARTMENT TO HOUSE (2) ZIAMATIC PORTABLE O2 HOLDERS		
L3 BACK CORNERS TO HOLD (2) SCBA TANK MOUNTS AND (3) ADJUSTABLE SHELVES		
ADDITIONAL O2 PORT IN CEILING OVER HEAD END OF COT		
CAPTAINS CHAIR TO HAVE ARM REST		
LED COMPARTMENT LIGHTS TO BE ROUND (NOT HANSEN STRIP LIGHTS)		



NEW

MARCH  
2022

**cfinch@jaspercountyga.org**

---

**From:** Bartley, David <dbartley@ten8fire.com>  
**Sent:** Monday, October 11, 2021 4:38 PM  
**To:** cfinch@jaspercountyga.org  
**Subject:** RE: Drawings for Demo that finishes in February  
**Attachments:** 2022 Std Features 2022 F-450 2156 Warrior10\_11\_21.docx

Chris,  
I attached the Line specifications and list of upgrades for the new Osage that finishes in Late February/early March.  
The price per the attached specifications is \$237,041.

All over red 2022 Demo is an awesome truck built for fire service. Has large streetside rear compartment.

Clayton, Cherokee, Hall all have Osage ambulances and have great service. Ten-8 service center in Forsyth is 30 minutes away.

Osage is a high quality truck and built to last.

**David Bartley**  
**Ambulance Sales | Ten-8 Fire & Safety LLC**

c: (407) 618-3140  
e: [dbartley@ten8fire.com](mailto:dbartley@ten8fire.com) | w: [ten8fire.com](http://ten8fire.com)



**From:** cfinch@jaspercountyga.org <cfinch@jaspercountyga.org>  
**Sent:** Monday, October 11, 2021 12:48 PM  
**To:** Bartley, David <dbartley@ten8fire.com>  
**Subject:** RE: Drawings for Demo that finishes in February

CAUTION: This email originated from outside your organization. Exercise caution when opening attachments or clicking links, especially from unknown senders.

Could you send me pricing on this and what size truck is it?

Chris

**From:** Bartley, David <dbartley@ten8fire.com>  
**Sent:** Thursday, October 7, 2021 4:51 PM  
**To:** Christopher Finch <cfinch@jaspercountyga.org>  
**Subject:** Drawings for Demo that finishes in February

Chris,

Glad I got to see you today. The drawings of the demo Ten-8 has available at beginning of March is attached.

David Bartley  
Ambulance Sales | Ten-8 Fire & Safety LLC

c: (407) 618-3140

e: [dbartley@ten8fire.com](mailto:dbartley@ten8fire.com) | w: [ten8fire.com](http://ten8fire.com)



**2022 OSAGE "2156" WARRIOR" TYPE I**  
**2022 FORD "F-450"**  
**STANDARD FEATURES**

- MEMBER AMD / NTEA & FORD QVM PROGRAM •
- CERTIFIED KKK-1822-F & ALL REVISIONS •
- CERTIFIED CAAS GVS V2.0 •

**CHASSIS**

- 2022 Ford F-450 w/ 47A Amb Prep Pkg
- 169" Wheel Base w/ Dual Rear Wheels
- GVWR: 16,500 LBS
- Front & Rear Stabilizer Bar
- 6.7 L Turbo Diesel w/ Ford Block Heater
- Ford Engine Hour Meter
- Ford Auxiliary Idler Control Unit
- Torqshift™ w/ SelectShift 10-Speed Automatic Transmission
- 4-Wheel Disc Brakes w/ ABS
- Stainless Steel Wheel Inserts
- Aluminum Diamond Plate Running Boards
- Rear Mud Flaps
- Dual Air Bags
- Dual Map Lights
- Tilt Steering Wheel & Cruise Control
- Electric Windows & Door Locks
- Keyless Remote Entry
- AM/FM Stereo Clock Radio w/ CD
- Deluxe Cloth High Back Captain's Chairs
- Rubber Floor Mat I.L.O. Carpet
- Ford OEM Mirrors, Heated and Power Adjust
- Daytime Running Lights
- Choice of 2WD

**MODULE**

- Module Dimensions:
  - 156" L x 87" H x 96" W
- Totally "Seamless" Body Construction
- Exterior Side & Roof Panels .125" Aluminum
- One-Piece Exterior Side Panels
- One-Piece Crowned Roof
- Frame Members 2" x 2" Aluminum Tubing
- Frame Members on 12" Centers
- Diamond Plate Shields:
  - \* Across Lower Rear of Body
  - \* Across Lower Front of Body
  - \* Lower 1/3 of Entry Doors
- All Exterior Doors "Pan-Formed" / Extruded Double Break Construction
- All Body Openings "Seamless"
- All Door Latches Mounted Behind Gaskets
- Exterior Compartment @ Front Left for Storage of Oxygen Tank and Back Boards
- Optional Curbside Backboard Storage
- Exterior Compartment Adjustable Shelving
- Exterior Compartment LED Lighting
- Cast "Grabber" Door Holders
- Lower Body Impact Rub Rails
- Polished Stainless Steel Fenderettes
- Grip Strut Rear Step Bumper w/ Flip-up Center Section 4" x 18" Dock Bumpers
- Automotive Undercoating

**WARNING SYSTEM**

- Two Red Whelen ION-T LED's Mounted in Chrome Flanges in Grill
- Two Red Whelen ION-T LED'S Mounted in Chrome Flanges in Front Fenders
- Eight Red LED Whelen M9 Modular Lights
- One Clear LED Whelen M9 Front Modular Light
- One Amber LED Whelen M9 Rear Modular Light
- Two Optic LED Whelen M9 Scene Lights per Side
- Two Optic LED Whelen M9 Rear Load Lights
- Primary / Secondary Switching
- Carson SA 400 Siren w/ Siren / Horn Switch
- Cast Siren Speaker
- Rear DOT Lighting Whelen LED 4x6 w/ Chrome Flanges: Red Tail / Brake, Amber Arrow Turn, Reverse
- LED Clearance / Marker Lights

**PAINT & MARKINGS**

- red Paint all over to match Race Red Chassis
- "No Smoking" & "Fasten Seat Belt" Signs

• Base Coat / Clear Coat Modular Paint

• Ambulance / Star-of-Life Decals

## 2022 Osage "2148 Warrior" Type I - 2022 Ford "F-450" - Standard Features

### ELECTRICAL

- Ford OEM Dual Alternators, Total 397 Amps.
- Digital Voltmeter
- Audible Low-Voltage Alarm
- Bosch, Vanner, Cole-Herse & Weldon Components
- Weldon V-Mux 100% Solid State Microprocessor Based Multiplex Electrical System
- Wiring Color-Coded and Heat Embossed Every 6" w/ Function
- Power Distribution Panel Easily Accessible Via Hinged Access Door in Action Area
- Front Switch Console Mounted on the Floor
- Hinge Mounted Attendant Switch Console
- Control Console Backlighting Dimmer
- Battery Switch Activated via Ignition Switch
- Open Door Warning Light
- Handheld LED Spotlight, Hardwired
- Whelen Dual Intensity LED Patient Compartment Dome Lights
- Exterior Weatherproof Shoreline Receptacle
- Two Interior 110V Duplex Receptacles
- Two Interior 12V Cigar Style Receptacles
- One Pre-Wire Antenna Cable
- Electrical Back-up Alarm w/ Auto Re-set

### INTERIOR

- 72" Interior Headroom
- 49" Aisle Width
- All Vertical Corners 1" Radii
- Stainless Steel Aisle Panel, Left Side, Full Length x 18" x .060"
- Lon-Plate nonskid Vinyl Flooring Rolled 3" Up Both Sides of Aisle
- EMT Seat, Pedestal Mounted Deluxe Vinyl Captains Chair w/ Child Seat & 6 point
- CPR Seat, Three Piece Molded, Contoured Cushions
- Squad Bench w/ Second Patient Capability
- All Seat Cushions Seamless
- Retractable Seat Belts for All Locations
- Handicap Style, 1 ½" Diameter, Full Length, Stainless Steel Overhead Grab Rail. This Rail shall be treated with Agion Anti-Bacterial Coating.
- Handicap Style, 1 ½" Diameter, Stainless Steel Door Pulls on Patient Compartment Doors. These Bars shall be treated with Agion Anti-Bacterial Coating.
- Double entry step on curbside entry door.
- Sliding "Pass-thru" Window between Cab and Patient Compartment
- Padded Bulk-Head Cabinet Doors
- Headliner Thermoplastic Sandwiched Between Two Sheets of Aluminum Finished in Semi-Gloss White
- ALS Compartment w/ In/Out Access
- 2 Adjustable & 1 Fixed Shelf in ALS
- R-29 Reflectix Insulation throughout Module
- Thermostatically Controlled Patient Compartment Heat & Cool System
- 3-Speed Manual Fan Control
- Rear Heat & Cool Unit Mounted Floor Level;
  - \* Moisture Drains Directly Through Floor
  - \* Short Coolant Circulation Distance
  - \* Eliminates Vertical Circulation of Coolant
  - \* Unit Easily Accessible for Maintenance
- Overhead Air Distribution w/ Floor Level Filtered Air Return for Optimum Circulation
- Two Recessed, Swing-up Dual IV Hangers
- "Zico" Retaining Bracket for Oxygen "M" Cyl
- Three "Ohio" Oxygen Outlets
- SSCOR Suction System
- Locking Sharps Container (Shipped Loose)
- Locking Drug Compartment
- Digital "Atomic" Clock w/ Seconds
- Stryker "Performance Load" Cot Fastener With Charging

### WARRANTY

- Three Year / 36,000 Mile Product Conversion
    - Five Year / 100,000 Mile Modular Paint
    - Seven Year / 72,000 Mile Electrical System
      - Lifetime Modular Body Structure
- "ALL WARRANTIES NON PRO-RATED"**  
NOTE: See Warranty Certificate for Details

**OSAGE AMBULANCE • P.O. BOX 718 • LINN, MO. 65051**  
**800-822-3634 • FAX: 573-897-3113**

[www.osageambulances.com](http://www.osageambulances.com)



## Upgrades

- **All Box Lights upgraded to Whelen M Series**
- **Remote head Siren with Dual Amps**
- **LED Rope Lighting in exterior compartments**
- **1,000 watt Inverter with Separate charger**
- **20 Amp Auto eject shoreline**
- **Two USB outlets**
- **Power locks on all compartment and patient doors**
- **External Condenser mounted on front of module**
- **Separate Compressor for Rear A/C**
- **Back Up Camera**
- **Zico Quick release spare O2 bottle holders**
- **6 point Harness for all seated positions**
- **Cargo Net at head of squad Bench**
- **All Aluminum interior cabinets**
- **Non wood sub floor**
- **Additional Glove storage**
- **Dropped Skirtline**
- **Wet Sand and Buff**
- **Power Pro Cot w/ Built in Charging in cot mount**
- **Rear Chevron High Visibility**



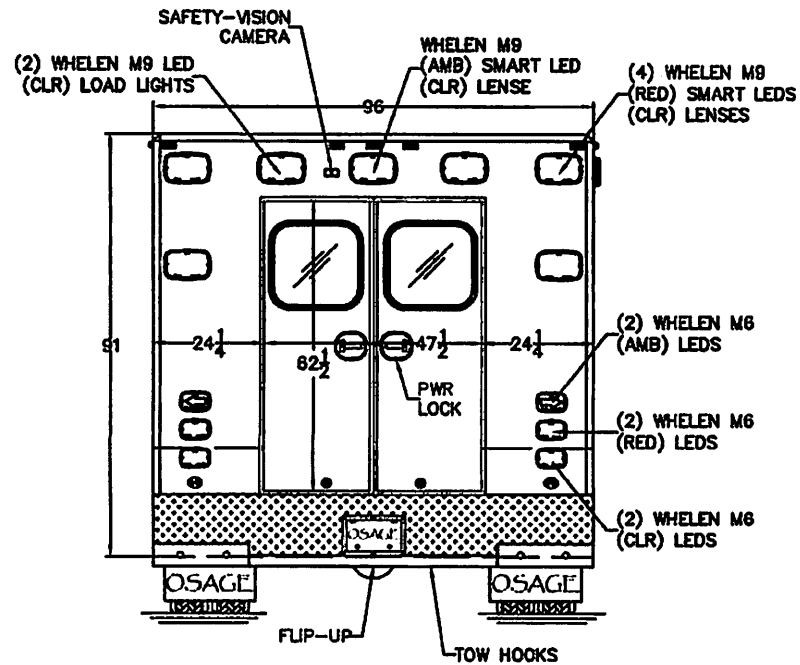
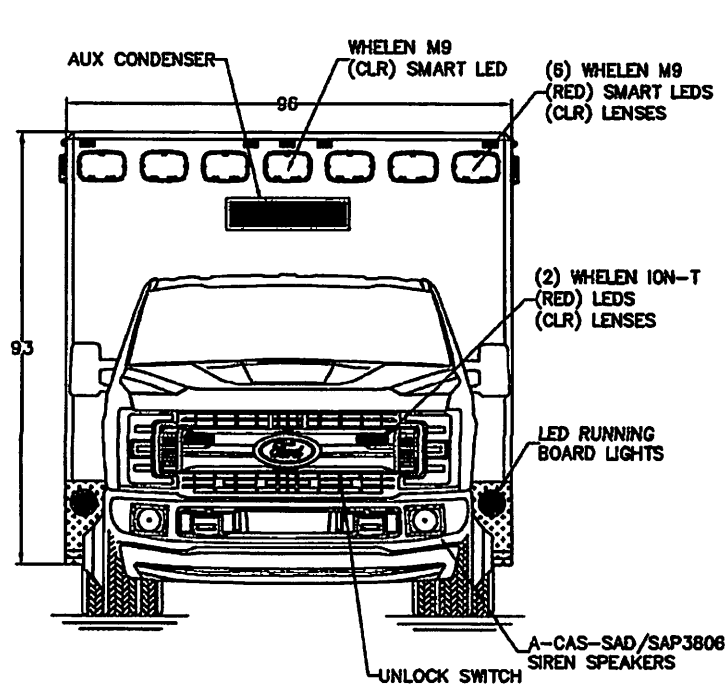

NOTES: THIS DRAWING IS NOT TO SCALE.  
CHARACTERISTICS AND DIMENSIONS OF FINISHED PRODUCT MAY VARY.

NOTES:

- 1.) COMPARTMENT DIMENSIONS REFLECT OPENING CLEARANCE.
- 2.) APPROXIMATE COMPARTMENT DEPTH=20 1/2"DEEP.
- 3.) MODULE DIMENSIONS=156"L x 96"W x 93"H
- 4.) INTERIOR MODULE HEAD ROOM=72"H.
- 5.) ALL 9x7 LIGHTS TO BE WHELEN M9 SERIES LIGHTS, CHROME FLANGES.
- 6.) DOUBLE STAINLESS THRESHOLDS.
- 7.) STYROFOAM INSULATION, WALLS & CEILING.
- 8.) TECHNIQUE LED STRIP-LIGHTS IN ALL COMPARTMENTS.
- 9.) DRY-DECK IN ALL COMPARTMENTS.

Stock/Job#:	J3155	Drawing#	J3155-100A	Cust. App'v/Date#	Deal'r App'v/Date:
Osage Dealer:	TEN-8 FIRE	<h1 style="margin: 0;">Osage Industries, Inc.</h1> <p style="margin: 0;">TWIN RIDGE ROAD      P.O. BOX 718      LINN, MO. 65051</p>			
End Customer:	DEMO				
<b>NOTICE</b>		Drawn By:	S.A.H.	Date:	08-23-21
This drawing and/or the information hereon is the exclusive property of Osage Industries and shall not be reproduced, used or disclosed without the authorized written consent of Osage Industries.		Drawing Description:			Scale:
		EXTERIOR LAYOUT, FRONT/REAR TYPE-I WARRIOR			NOT TO SCALE
Rev.#	Revision Description	Date	Rev'd	App'vd	Revision#

3					
2					
1	PRODUCTION DRAFT	08-23-21	SAH		
Rev.#	Revision Description	Date	Rev'd	App'vd	

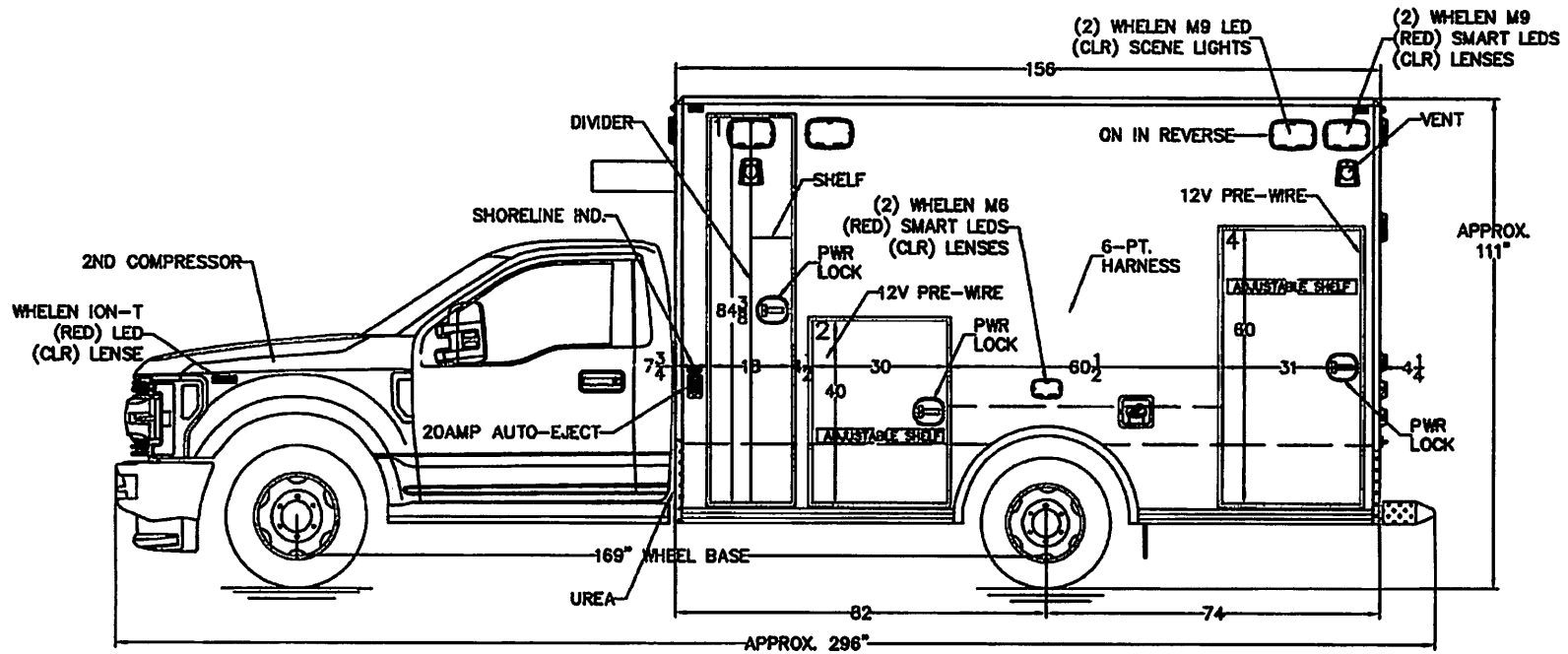

NOTES: THIS DRAWING IS NOT TO SCALE.  
CHARACTERISTICS AND DIMENSIONS OF FINISHED PRODUCT MAY VARY.

NOTES:

- 1.) COMPARTMENT DIMENSIONS REFLECT OPENING CLEARANCE.
- 2.) APPROXIMATE COMPARTMENT DEPTH=20 1/2"DEEP.
- 3.) MODULE DIMENSIONS=156"L x 96"W x 93"H
- 4.) INTERIOR MODULE HEAD ROOM=72"H.
- 5.) ALL 9x7 LIGHTS TO BE WHELEN M9 SERIES LIGHTS, CHROME FLANGES.
- 6.) DOUBLE STAINLESS THRESHOLDS.
- 7.) STYROFOAM INSULATION, WALLS & CEILING.
- 8.) TECHNIQUE LED STRIP-LIGHTS IN ALL COMPARTMENTS.
- 9.) DRY-DECK IN ALL COMPARTMENTS.

Stock/Job#:	J3155	Drawing#	J3155-1008	Cust. App'v/Date#	Dea'r App'v/Date:
Osage Dealer:	TEN-8 FIRE	<b>Osage Industries, Inc.</b> TWIN RIDGE ROAD P.O. BOX 718 LINN, MO. 65051			
End Customer:	DEMO				
<b>NOTICE</b>		Drawn By:	S.A.H.	Date:	08-23-21
This drawing and/or the information hereon is the exclusive property of Osage Industries and shall not be reproduced, used or disclosed without the authorized written consent of Osage Industries.		Drawing Description:			Scale:
		EXTERIOR LAYOUT, STREETSIDE TYPE-I WARRIOR			NOT TO SCALE
Rev.#	Revision Description	Date	Rev'd	App'vd	Revision#

3					
2	REVISION DRAFT	08-24-21	SAH		
1	PRODUCTION DRAFT	08-23-21	SAH		
Rev.#	Revision Description	Date	Rev'd	App'vd	

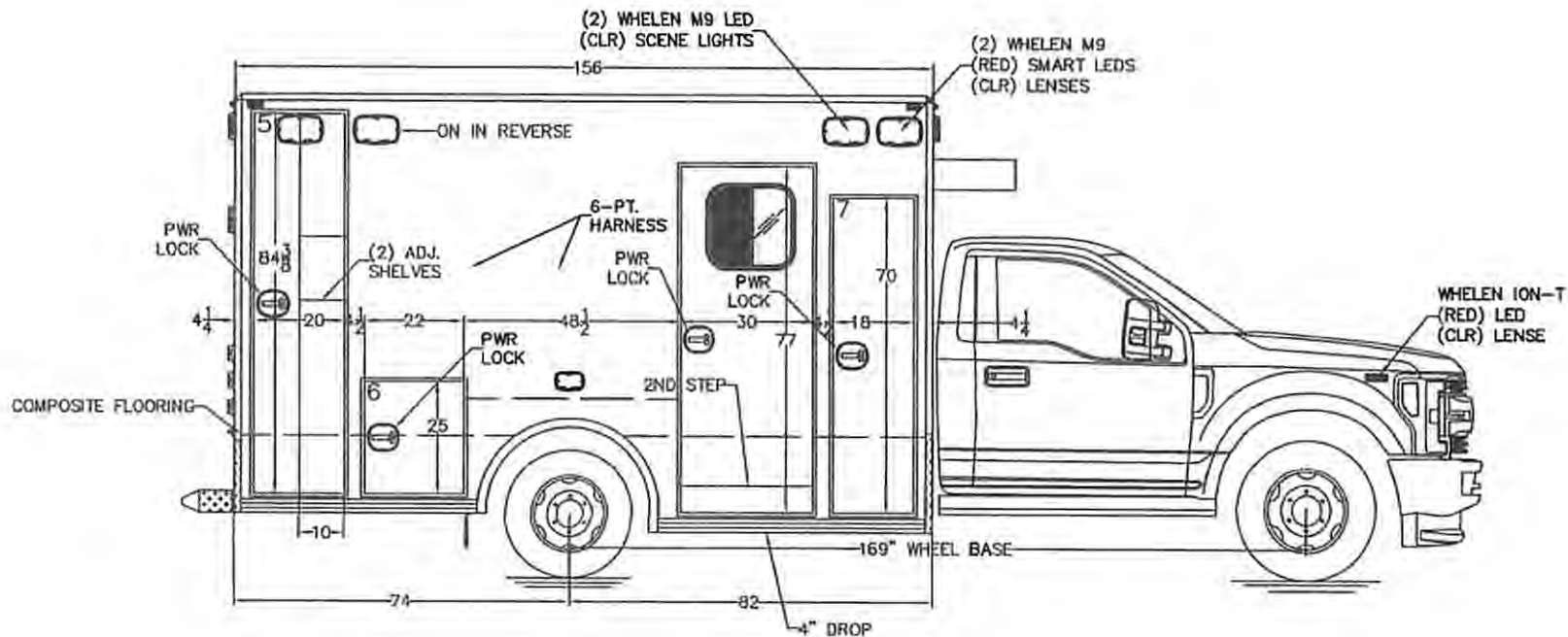

NOTES: THIS DRAWING IS NOT TO SCALE.  
CHARACTERISTICS AND DIMENSIONS OF FINISHED PRODUCT MAY VARY.

NOTES:

- 1.) COMPARTMENT DIMENSIONS REFLECT OPENING CLEARANCE.
- 2.) APPROXIMATE COMPARTMENT DEPTH=20 1/2"DEEP.
- 3.) MODULE DIMENSIONS=156"L x 96"W x 93"H
- 4.) INTERIOR MODULE HEAD ROOM=72"H.
- 5.) ALL 9x7 LIGHTS TO BE WHELEN M9 SERIES LIGHTS, CHROME FLANGES.
- 6.) DOUBLE STAINLESS THRESHOLDS.
- 7.) STYROFOAM INSULATION, WALLS & CEILING.
- 8.) TECHNIQUE LED STRIP-LIGHTS IN ALL COMPARTMENTS.
- 9.) DRY-DECK IN ALL COMPARTMENTS.

Stock/Job#:	J3155	Drawing#	J3155-100C	Cust. App'v/Date#	Deal'r App'v/Date:
Osage Dealer:	TEN-8 FIRE	<b>Osage Industries, Inc.</b> TWIN RIDGE ROAD P.O. BOX 718 LINN, MO. 65051			
End Customer:	DEMO				
<b>NOTICE</b>		Drawn By:	S.A.H.	Date:	08-23-21
This drawing and/or the information hereon is the exclusive property of Osage Industries and shall not be reproduced, used or disclosed without the authorized written consent of Osage Industries.		Drawing Description:			Scale:
		EXTERIOR LAYOUT, CURBSIDE TYPE-I WARRIOR			NOT TO SCALE
Rev.#	Revision Description	Date	Rev'd	App'vd	Revision#

3					
2					
1	PRODUCTION DRAFT	08-23-21	SAH		
Rev.#	Revision Description	Date	Rev'd	App'vd	

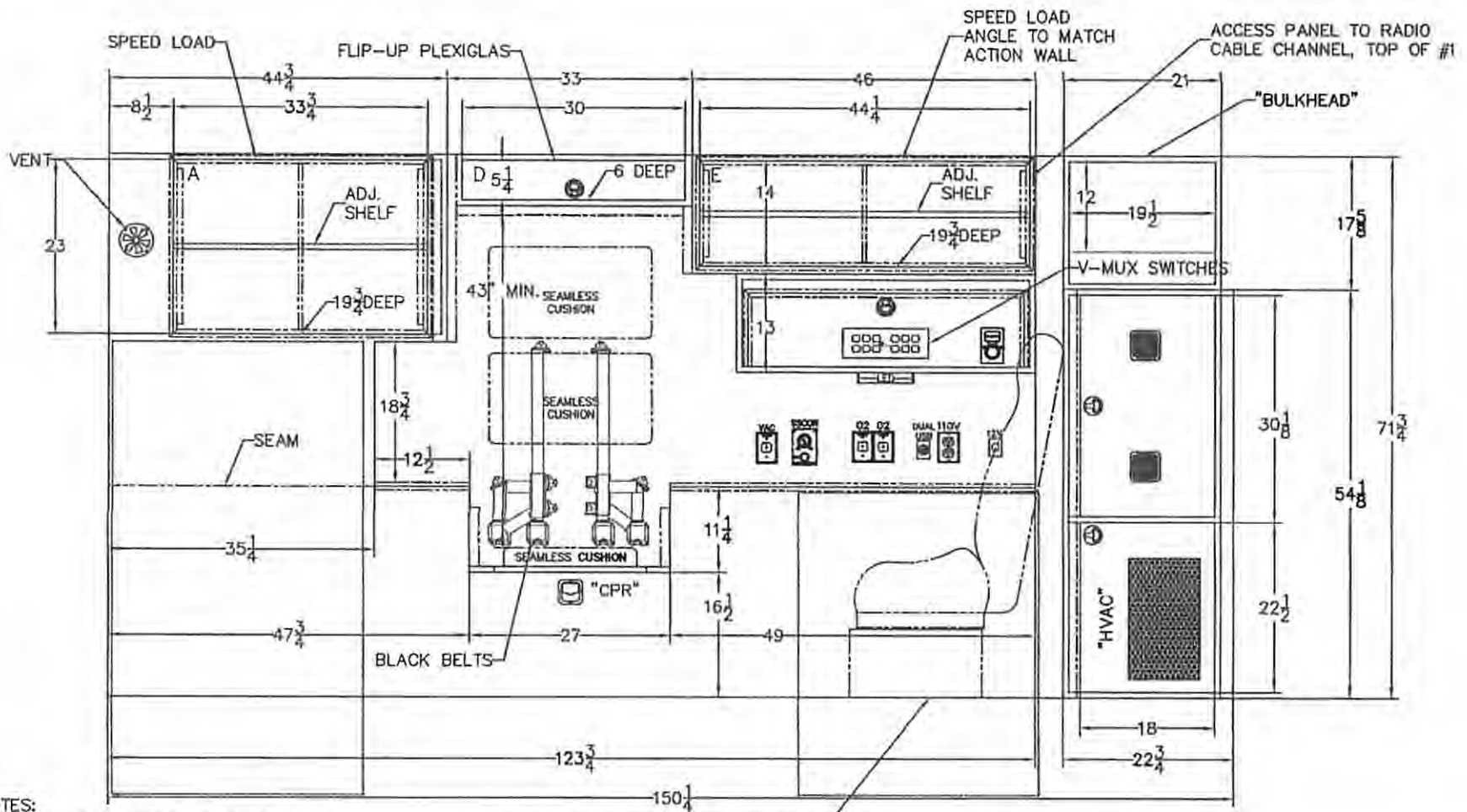

- NOTES:  
 1.) ALUMINUM CABINETS, MARBLESTONE.  
 2.) S.S. SOUTHCOS.

NOTES: THIS DRAWING IS NOT TO SCALE.  
 CHARACTERISTICS AND DIMENSIONS OF FINISHED PRODUCT MAY VARY.

NOTES: CABINET DEPTHS REPRESENT DIMENSION FROM INSIDE REAR TO FRONT FACE OF CABINETS, WITHOUT TRIM. ACTUAL WORKING DEPTH WILL BE LESS THAN DIMENSION SHOWN UNLESS OTHERWISE SPECIFIED.

E.V.S. 6-PT. CHILD/ATTENDANT SEAT

Stock/Job#:	J3155	Drawing#	J3155-101	Cust. App'v/Date#	Deal'r App'v/Date:
Osage Dealer:	TEN-8 FIRE	<b>Osage Industries, Inc.</b> TWIN RIDGE ROAD P.O. BOX 718 LINN, MO. 65091			
End Customer:	DEMO				
<b>NOTICE</b> This drawing and/or the information hereon is the exclusive property of Osage Industries and shall not be reproduced, used or disclosed without the authorized written consent of Osage Industries.		Drawn By:	S.A.H.	Date:	08-23-21
		Drawing Description:			Scale:
			STREETSIDE INTERIOR TYPE-I WARRIOR		Revision# 1

Rev.#	Revision Description	Date	Rev'd	App'vd
3				
2	REVISION DRAFT	08-24-21	SAH	
1	PRODUCTION DRAFT	08-23-21	SAH	

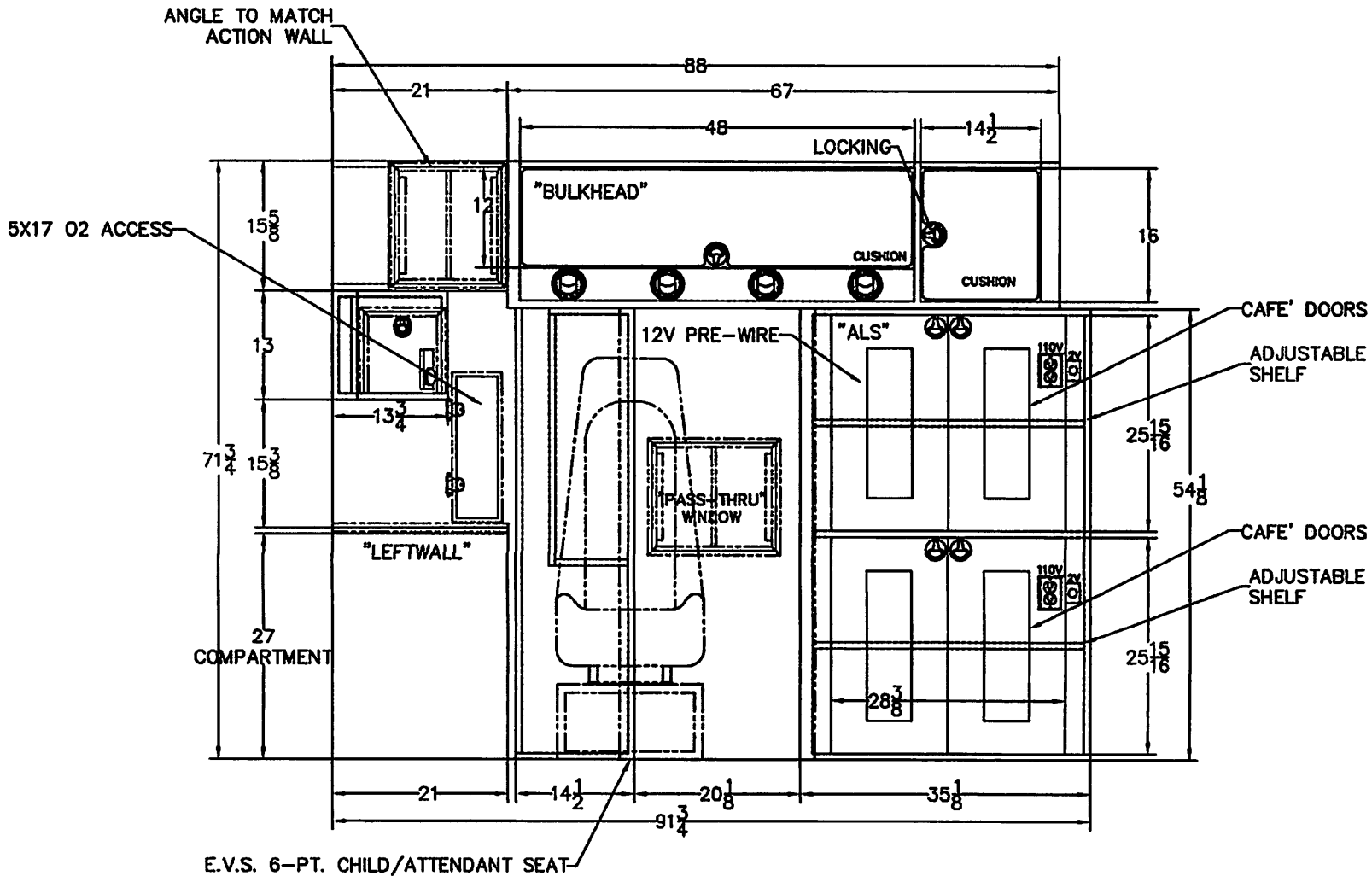

NOTES: THIS DRAWING IS NOT TO SCALE.  
CHARACTERISTICS AND DIMENSIONS OF FINISHED PRODUCT MAY VARY.

NOTES: CABINET DEPTHS REPRESENT DIMENSION FROM  
INSIDE REAR TO FRONT FACE OF CABINETS, WITHOUT TRIM.  
ACTUAL WORKING DEPTH WILL BE LESS THAN DIMENSION  
SHOWN UNLESS OTHERWISE SPECIFIED.

Stock/Job#:	J3155	Drawing#	J3155-102	Cust. App'v/Date#	Deal'r App'v/Date:
Osage Dealer:	TEN-8 FIRE	<b>Osage Industries, Inc.</b>			
End Customer:	DEMO				
		TWIN RIDGE ROAD	P.O. BOX 718	LINN. MO. 65051	
<b>NOTICE</b>		Drawn By:	S.A.H.	Date:	08-23-21
		Scale: NOT TO SCALE			
This drawing and/or the information hereon is the exclusive property of Osage Industries and shall not be reproduced, used or disclosed without the authorized written consent of Osage Industries.		Drawing Description:			Revision#
		FORWARD INTERIOR TYPE-I WARRIOR			1

3				
2				
1	PRODUCTION DRAFT	08-23-21	SAH	.
Rev.#	Revision Description	Date	Rev'd	App'vd

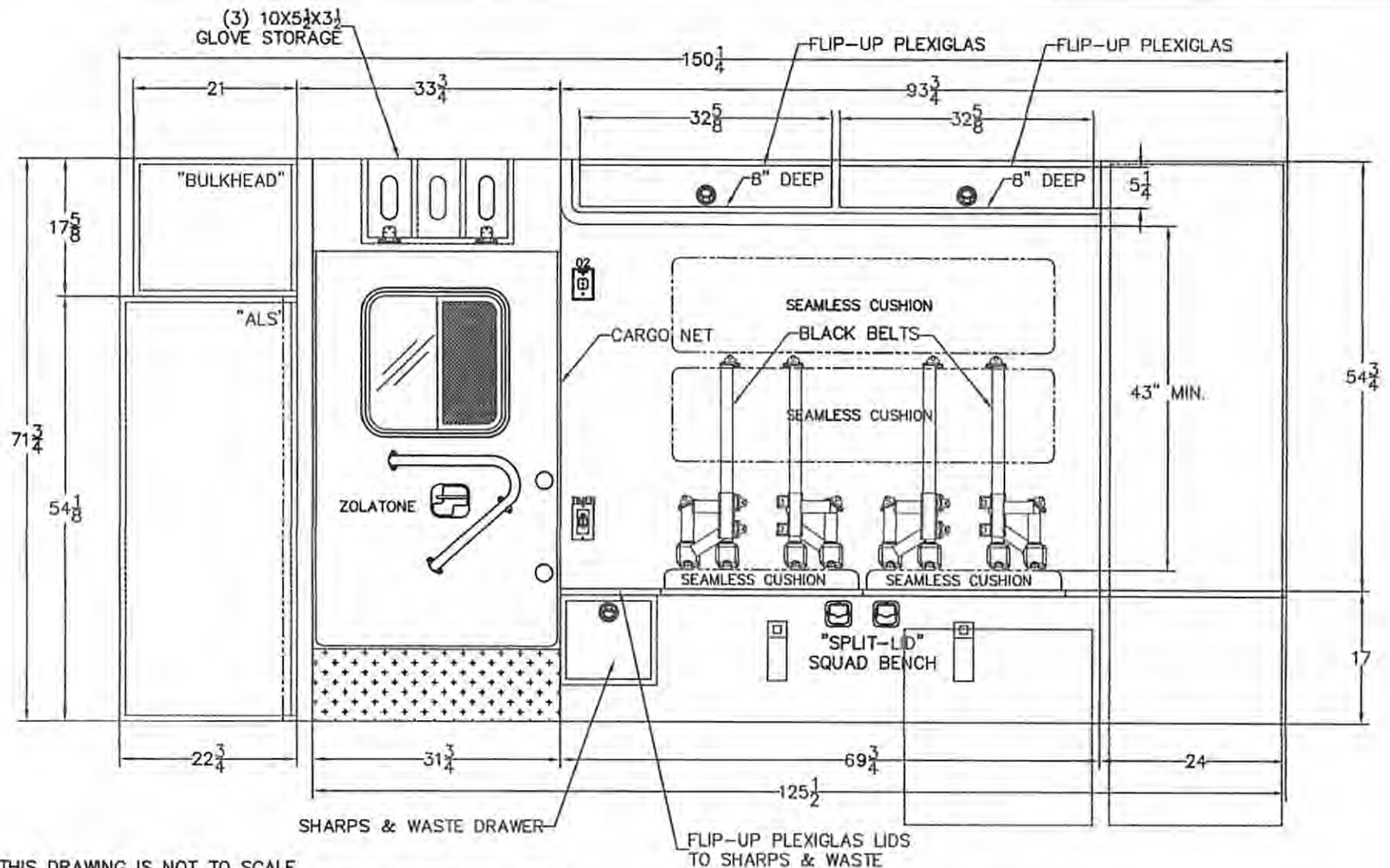

NOTES: THIS DRAWING IS NOT TO SCALE.  
CHARACTERISTICS AND DIMENSIONS OF FINISHED PRODUCT MAY VARY.

NOTES: CABINET DEPTHS REPRESENT DIMENSION FROM INSIDE REAR TO FRONT FACE OF CABINETS, WITHOUT TRIM. ACTUAL WORKING DEPTH WILL BE LESS THAN DIMENSION SHOWN UNLESS OTHERWISE SPECIFIED.

Stock/Job#:	J3155	Drawing#	J3155-103	Cust. App'v/Date#	Deal'r App'v/Date:
Osage Dealer:	TEN-8 FIRE	<b>Osage Industries, Inc.</b> TWIN RIDGE ROAD P.O. BOX 718 LINN, MO. 65051			
End Customer:	DEMO			Drawn By:	S.A.H.
<b>NOTICE</b> This drawing and/or the information hereon is the exclusive property of Osage Industries and shall not be reproduced, used or disclosed without the authorized written consent of Osage Industries.		Drawing Description:		Scale:	NOT TO SCALE
		CURBSIDE INTERIOR TYPE-1 WARRIOR		Revision#	1

Rev.#	Revision Description	Date	Rev'd	App'vd
3				
2				
1	PRODUCTION DRAFT	08-23-21	SAH	



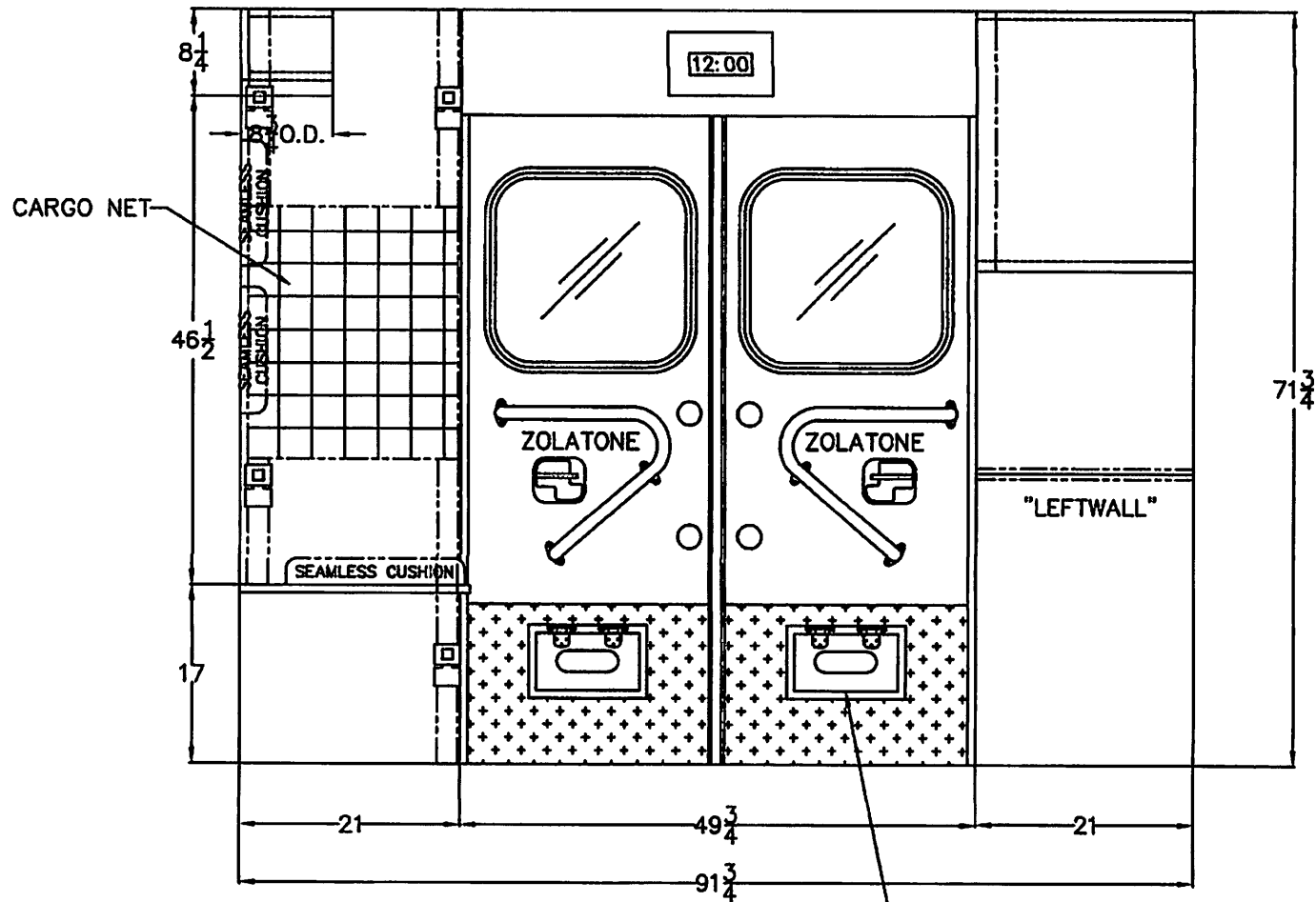

NOTES: THIS DRAWING IS NOT TO SCALE.  
 CHARACTERISTICS AND DIMENSIONS OF FINISHED PRODUCT MAY VARY.

NOTES: CABINET DEPTHS REPRESENT DIMENSION FROM  
 INSIDE REAR TO FRONT FACE OF CABINETS, WITHOUT TRIM.  
 ACTUAL WORKING DEPTH WILL BE LESS THAN DIMENSION  
 SHOWN UNLESS OTHERWISE SPECIFIED.

Stock/Job#:	J3155	Drawing#	J3155-104	Cust. App'v/Date#	Deai'r App'v/Date:
Osage Dealer:	TEN-8 FIRE	Osage Industries, Inc.		TWIN RIDGE ROAD P.O. BOX 718 LINN, MO. 65051	
End Customer:	DEMO				
NOTICE		Drawn By:	S.A.H.	Date:	08-23-21
		Drawing Description:		Scale:	NOT TO SCALE
This drawing and/or the information hereon is the exclusive property of Osage Industries and shall not be reproduced, used or disclosed without the authorized written consent of Osage Industries.		REARWARD INTERIOR TYPE-I WARRIOR		Revision#	
				1	

3				
2				
1	PRODUCTION DRAFT	08-23-21	SAH	
Rev.#	Revision Description	Date	Rev'd	App'vd

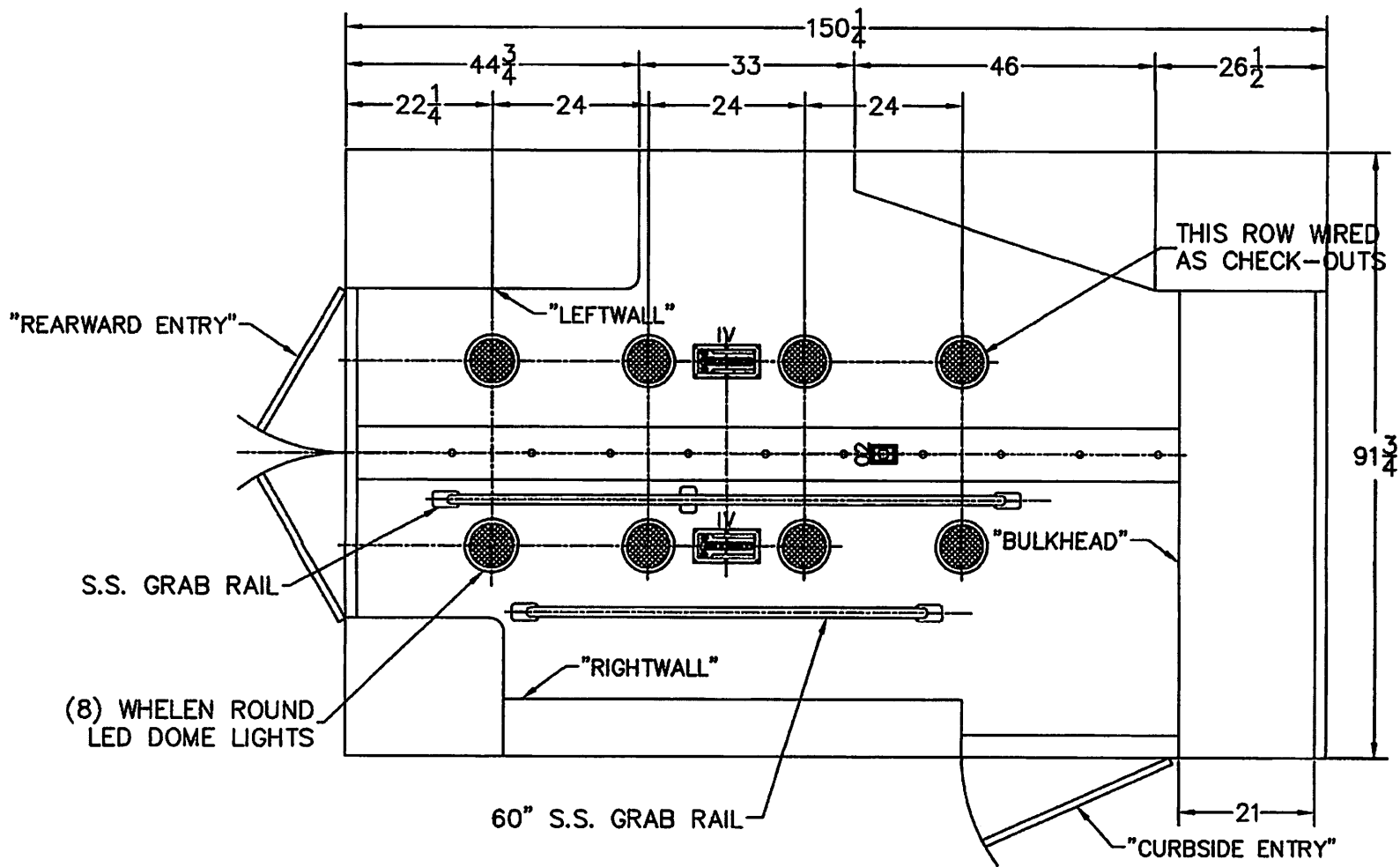

NOTES: THIS DRAWING IS NOT TO SCALE.  
 CHARACTERISTICS AND DIMENSIONS OF FINISHED  
 PRODUCT MAY VARY.

Stock/Job#:	J3155	Drawing#	J3155-105	Cust. App'v/Date#	Deal'r App'v/Date:
Osage Dealer:	TEN-8 FIRE	<b>Osage Industries, Inc.</b> TWIN RIDGE ROAD P.O. BOX 718 LINN, MO. 65051			
End Customer:	DEMO				
<b>NOTICE</b> This drawing and/or the information hereon is the exclusive property of Osage Industries and shall not be reproduced, used or disclosed without the authorized written consent of Osage Industries.		Drawn By:	S.A.H.	Date:	08-23-21
		Drawing Description:			Scale:
			CEILING LAYOUT		Revision#
			TYPE-I WARRIOR		
Rev.#	Revision Description	Date	Rev'd	App'vd	1

3				
2				
1	PRODUCTION DRAFT	08-23-21	SAH	
Rev.#	Revision Description	Date	Rev'd	App'vd



# Shop Order

SPECIALTY DEMO  
JIM PHILIPS

SPECIALTY DEMO

Exp. Date: 07/30/2021  
 Quote No: 11346-0001  
 GENERAL: REMGEN \*\*\*\*\*BID STANDARDS\*\*\*\*\*  
 TYPE: REM01 Remount, Base, Conversion  
 BASE: REMPR Remount, Base

07/19/2021

Job/Order No: 28129R 22OF SPECIALT

Page 1

PART NO	S	DESCRIPTION	QTY
== *****BID STANDARDS***** - 20.001 06/28/21 ==			7
00-10-0015		Vehicle Quantity (Vehicles)	1
00-91-0001	S	ORIGINAL MAUFACTURER AND ORIGINAL BODY NUMBER: WHEELED COACH 311045	1
00-91-0003	S	CHASSIS VIN NUMBER: 1FDUF4GT1BEA48356	1
00-91-0015		ACCOUNT MANAGER: Tammy Roten	1
00-91-000Y	S	1st Original Manufacturing Completion Date: 2011	1
00-91-0027	S	REFERENCE UNIT #: 311045	1
00-91-0028	S	RE-WRITE DATE : 6/30/21	1
00-91-0040		SEAT BELT POSITIONS MODS	1
00-91-0042		- CAB SEAT BELT MOD:	1
00-91-0044		- Total: 2 Positions	1
00-91-0050		- REAR SEAT BELT MOD:	1
00-91-0053		- Total: FILL IN NUMBER OF POSITIONS	1
00-99-9000		Revision Level: 0 - Zero - ORIGINAL VERSION	1
00-99-9030		Change Order Level: 0 - Zero - ORIGINAL VERSION	1
== Remount, Base, Conversion - 20.001 06/28/21 ==			7
GENERAL REMOUNT QUESTIONS			1
50-00-0015		- Modular Body Mfg: Wheeled Coach	7
50-10-0030		- Previous Chassis: Ford F-450 - Cab Chassis	7
50-20-0010		- Previous Cab to Body: Window Only - Talk thru	7
01-AR-1F51	S	- 2022 Ford, F-450 4 x 4 DRW Reg Cab, 193" WB, XLT Turbo Diesel	7
SPECIAL ORDER CHASSIS			
ADJ SEATS			
NAVIGATION			
SYNC 3			
OEM BACK UP PUSH BUTTON LOCK KEYPAD			
ADJ FLOOR PEDALS			
01-1F-0086		- Engine: 6.7L Scorpion, Pwr Stroke V-8 Turbo Diesel - F-series 2020+	7
01-1F-0092		- Chassis Front engine hood Insulation Not included by OEM Ford on all XLT	7
01-1F-0101		- 98R- Operator Command Regeneration	7
01-1F-02CM		- Cab Interior Color: Medium Earth Gray F-series	7
01-1F-02T5		- F-Series 193" wheelbase reg cab LWB	7
01-1F-04PR		- GVWR: 16,500 pounds, FAWR: 7,000, RAWR: 12,000	7
01-FL-TI06		- Tire, SPARE: Matching, Random Make	7
01-FM-TI01		- Location: Shipped Loose	7
01-TU-0112		- Jack and Tire Tools: Install behind Passenger's seat	7
01-FM-4WH1		- Wheel Finish: Polished SS Wheel Simulators (F-450)	7
01-FM-DL01		- Cab Door Locks: Power XLT- Auto Lock,Auto Unlock Standard	7
01-FM-DTRL		- Daytime Running Lights: Ford OEM	7
01-FM-DTRQ		- Ford F series High center mount brake light ordered with chassis	7

PART NO	S	DESCRIPTION	QTY
01-FM-TIR3		/-- Tires: F-4/550, All season, Random Mk 225/70 R19.5, LR F	1
01-OE-47LF		/-- 47L - Ambulance Prep Package - F-Series	1
01-OE-47A5		/-- Alternators Dual (OEM) Motorcraft Ford 67B 2017+ Ford F super duty	1
01-OE-47C0		/-- Throttle Control System	1
01-RR-05B6		/-- Radio, F-series: OEM AM/FM/Satellite w/ 5 cab speakers 8" Display 2020 +	1
01-SY-0000		/-- Ford SYNC Basic installed Enhanced voice recognition	1
03-EA-47PR		/-- Side Mirrors, OEM (F-Series), Pwr Glass, Heated, manual Telescopic	1
04-SU-1101		/-- Ford OEM Front Suspension Coil Spring Std F-450/550	1
04-SU-1727	XS	/-- Rear Suspension: F-450 108 cab to axle Liquid Spring, 2017 + *NOTE: If Oxygen Lift is installed, then if the O2 Cmptr Door is open, the kneeling suspension will not dump until door is closed* SUSP-DS129FS3	1
01-TT-0208		/-- ""DETAIL"" Liquid Rear Suspension Decal Install Prior to delivery, detail department is to install a Black Decal on the dash:	1
04-SU-03F6		/-- Rear Stabilize (Anti-Sway) Bar: OEM, Ford F-450/550	1
04-SU-0602	S	/-- Kneeling Feature: Enable Switch Located in M5 Filler Switch location shall be within reach of an attendant standing on the ground, outside the module. It shall be recessed from the wall surface.	1
04-SU-0612		/-- LOCATION: Sw panel on Face of CS cabinets near RA door	1
04-SU-0610		/-- Kneeling Feature: Activated by TRAILING rear access door	1
04-SU-0651		/-- Exhaust system termination point: OEM Location, Rt Rear	1
04-SU-2022		/-- Liquid spring controller shipped loose with completed unit Dealer to install with customer on arrival	1
50-60-0010		/-- Previous Fuel Type: Diesel	1
50-61-0010		/-- Desired Fuel Type: Diesel	1
50-SF-2KAR		/-- Vehicle Built to Mass Specs	1
50-70-000N		/-- No	1
ZZ-ZZ-ZZZY		/--	1
ZZ-ZZ-ZZZZ		/--	1
51-BC-0030		Unit Bio-Cleaned : Unit Cleaned at REV Solutions	1
		BODY	1
52-00-0003		/-- ALL DIMENSIONS ON ORDER WILL HAVE A VARIABLE OF + OR - 1/4" Unless specified as a minimum dimension.	1
52-20-0083		/-- Modular Body: 168 x 95 x 72HR	1
52-40-0012		/-- Body Compartment: M1 (Left Front) - On Body Single Door	1
52-40-0130		/-- Single Door	1
52-B0-0010		/-- Compt Door Checks: Leave Existing	1
52-B0-0050		/-- Compt Door Inner Panels : Leave Existing	1
52-B0-WC09		/-- Module Door Wheeled Coach Gasket D Profile, Spaced Holes, Replace w/Overall Pnt	1
52-BT-C910		/-- Trimark 030-1875 Free Floating Chrome Handle: for Cmptr M1 Replace handles, rods, rotary latches and nader pins	1
52-40-0016		/-- Body Compartment: M1.5 (Left Front Upper) - None	1
52-40-0023		/-- Body Compartment: M2 (Left Middle) - On Body Double Doors	1
52-40-0140		/-- Double Doors	1
52-B0-0010		/-- Compt Door Checks: Leave Existing	1
52-B0-0050		/-- Compt Door Inner Panels : Leave Existing	1
52-B0-WC09		/-- Module Door Wheeled Coach Gasket D Profile, Spaced Holes, Replace w/Overall Pnt	1

QTY	PART NO	DESCRIPTION	S
1	52-BT-C995	-- TriMark 030-1875 Free Floating Chrome Handle: for Double Doors Replace handles, rods, rotary latches and nader pins	
1	52-B0-0026	-- Body Compartment: M2.5 (Left Middle Upper or WW) - None	
1	52-40-0033	-- Body Compartment: M3 (Left Rear) - On Body Double Door	
1	52-40-0140	-- Double Doors	
1	52-B0-0010	-- Compt Door Checks: Leave Existing	
1	52-B0-0050	-- Compt Door Inner Panels : Leave Existing	
1	52-B0-WC09	-- Module Door Wheeled Coach Gasket D Profile, Spaced Holes, Replace w/Overall Pnt	
1	52-BT-C995	-- TriMark 030-1875 Free Floating Chrome Handle: for Double Doors Replace handles, rods, rotary latches and nader pins	
1	52-40-0040	-- Body Compartment: M4 (Rear Left) - None	
1	52-40-0046	-- Body Compartment: M4a (Rear Right) - None	
1	52-40-0052	-- Body Compartment: M5 (Right Rear) - On Body Single Door	
1	52-40-0130	-- Single Door	
1	52-B0-0010	-- Compt Door Checks: Leave Existing	
1	52-B0-0050	-- Compt Door Inner Panels : Leave Existing	
1	52-B0-WC09	-- Module Door Wheeled Coach Gasket D Profile, Spaced Holes, Replace w/Overall Pnt	
1	52-BT-C950	-- TriMark 030-1875 Free Floating Chrome Handle: for Cmpt M5 Replace handles, rods, rotary latches and nader pins	
1	52-40-0053	-- Body Compartment: M5.5 (Right Rear WW) - None	
1	52-40-0130	-- Single Door	
1	52-B0-0010	-- Compt Door Checks: Leave Existing	
1	52-B0-0050	-- Compt Door Inner Panels : Leave Existing	
1	52-B0-WC09	-- Module Door Wheeled Coach Gasket D Profile, Spaced Holes, Replace w/Overall Pnt	
1	52-BT-C960	-- TriMark 030-1875 Free Floating Chrome Handle: for Cmpt M6 Replace handles, rods, rotary latches and nader pins	
1	52-40-0072	-- Body Compartment: M7 (Right Front ALS) - On Body	
1	52-40-0130	-- Single Door	
1	52-B0-0010	-- Compt Door Checks: Leave Existing	
1	52-B0-0050	-- Compt Door Inner Panels : Leave Existing	
1	52-B0-WC09	-- Module Door Wheeled Coach Gasket D Profile, Spaced Holes, Replace w/Overall Pnt	
1	52-BT-C970	-- TriMark 030-1875 Free Floating Chrome Handle: for Cmpt M7 Replace handles, rods, rotary latches and nader pins	
1	52-40-0082	-- Body Compartment: M8 (Right Front Lower) - On Body	
1	52-40-0130	-- Single Door	
1	52-B0-0010	-- Compt Door Checks: Leave Existing	
1	52-B0-0050	-- Compt Door Inner Panels : Leave Existing	
1	52-B0-WC09	-- Module Door Wheeled Coach Gasket D Profile, Spaced Holes, Replace w/Overall Pnt	
1	52-BT-C980	-- TriMark 030-1875 Free Floating Chrome Handle: for Cmpt M8 Replace handles, rods, rotary latches and nader pins	
1	52-40-0090	-- Body Compartment: M9 (Right Front FWD B/B) - None	
1	52-40-0112	-- Body Entry Curbside: On Body	

PART NO	S	DESCRIPTION	QTY
52-B0-WC09		/-- Module Door Wheeled Coach Gasket D Profile, Spaced Holes, Replace w/Overall	1
	Pnt		
52-B0-09B0		/-- C/S Door Check : Leave Existing	1
04-EA-09B1		/-- Door Swing Angle: Set to 90-100 degrees	1
52-BT-D003		/-- Install New Tri-mark 030-1875, free float for C/S Entry	1
52-BT-C875		/-- Wheeled Coach Emergency Release Latches (C/S)	1
52-40-0122		/-- Body Entry Rear: On Body - Double Doors	1
52-B0-WC09		/-- Module Door Wheeled Coach Gasket D Profile, Spaced Holes, Replace w/Overall	1
	Pnt		
52-B2-0010		/-- Rear Door Hold Opens: None - Leave Existing	1
52-BT-D004		/-- Trimark 030-1875 Free Floating Chrome Handle: for Rear Entry Doors (Pair)	1
		Replace handles, rods, rotary latches and nader pins	
52-BT-C874		/-- Wheeled Coach Emergency Release Latches (Rear)	1
52-B4-0010		/-- Curbside Stepwell: Leave Existing	1
52-BT-D000		/-- Install new Handles Trimark 1875 Free Float Chrome	1
ZZ-ZZ-ZZZY		/--	1
ZZ-ZZ-ZZZZ		/--	1
		<b>GENERAL CONVERSION WELDING &amp; BODY REPAIR :</b>	
53-00-0004	S	/-- Weld and Repair Side Marker Light Holes and Front 900 Light Hole	1
		REAR BACK UP CAMERA HOLES	
		REAR TRAFFIC ADVISOR HOLES	
		REAR 700 SCENE LIGHT HOLES	
		REAR CENTER 700 LIGHT HOLES	
		4 REAR 700 WINDOW LEVEL LIGHT HOLES	
53-00-0010		/-- Modify Doors for 1875 Handles	1
53-00-0014		/-- No Installation structure in curb side wall and CPR for 6 point seat belts req	1
53-00-0020		/-- No Reskin Necessary	1
ZZ-ZZ-ZZZY		/--	1
ZZ-ZZ-ZZZZ		/--	1
		<b>WELDING - Station No 1</b>	
54-BP-F364		/-- BODY PROTECTION AND TRIM PACKAGE: Cutaway Chassis	1
54-AS-0610		/-- Fuel Fill: CPI C1045, Open Housing, Polished Bezel	1
		Part No: HOUS-1045	
54-AS-0620		/-- Fuel over Fill protection plate: None	1
54-AS-0800		/-- Urea Fill: CPI FG4503-1-163 Inlet Housing	1
54-AS-1800		/-- Cmpt Stainless Steel - Sill protection: None	1
ZZ-ZZ-ZZZZ		/--	1
54-BW-7A10		/-- Bumper, Rear: HD Alum Framed w/DP pontoon covers	1
54-EA-LA00		/-- Step Latch Bolt: No additional latch bolt	1
ZZ-ZZ-ZZZZ		/--	1
54-BW-AF20		/-- Fenders, Rear: Rubber Extruded, Black	1
54-BW-AF2R		/-- Install: (2) Fender Rings behind Blk Rubber Fender Flairs	1
		Install Fender Rings behind Black Rubber Fender Flairs	
54-BW-RU01		/-- Skirt Rails: Extruded Rubber	1
		ILO Diamond Plate Skirt rails	
ZZ-ZZ-ZZZZ		/--	1
54-BW-DP06		/-- Corner Caps: 17.3" High, Alum Diamond Plate, (4)	1
		If there is a body drop, add the appropriate height to Corner Caps.	
ZZ-ZZ-ZZZZ		/--	1
54-BW-DP08		/-- Front Stone Guards: Alum Diamond Plate	1
		If there is a body drop, add the appropriate height to Stone Guards.	

PART NO	S	DESCRIPTION	QTY
ZZ-ZZ-ZZZZ		/--	1
54-BW-DP14		/-- Rear Kick Plate: Polished Aluminum Diamond Plate	1
54-AS-0507		/-- Holder, License Plate, CPI LP0002-1-D-UA with LED lights	1
		Delete standard Tag cut out.	
		Comes complete with two lights installed LED,	
		HOLD-21DUA	
04-AS-0520		/-- Location, kickplate centered under rear doors	1
55-EL-44TN		/-- Tag Light: Kinequip LED	1
ZZ-ZZ-ZZZZ		/--	1
ZZ-ZZ-ZZZZ		/--	1
54-EA-11RB		/-- Mud Flaps Front: Incorporated into Running Boards	1
ZZ-ZZ-ZZZZ		/--	1
54-EA-1131		/-- Mud Flaps Rear: Rev Solutions	1
54-EA-14A4		/-- Running Boards, Diamond Plate, w/ Grip strut inserts, T1 Ford	1
ZZ-ZZ-ZZZZ		/--	1
54-MH-2500		/-- Drive Shaft Loop: None	1
54-EA-3101	S	/-- Auxiliary Step: Leave Existing	1
56-EA-01FD		/-- Tire Valve Extensions, S/S Braided, PR, Dual Rear Wheel, Ford chassis	1
		Ford Chassis	
ZZ-ZZ-ZZZZ		/--	1
ZZ-ZZ-ZZZY		/--	1
ZZ-ZZ-ZZZZ		/--	1
		EXT LIGHTING / AC / INSULATION - Station No 2	1
55-EL-1450		/-- Front Turn, Whelen M6 Series w/arrow, LED, Pair, IATS	1
05-EL-1202		/-- Location: Front of Module, Below Outer Warning Lights	1
05-PH-LF21		/-- M6 Series Conversion Flange Pkg: Each	2
55-EL-18W1		/-- ICC Light Package Wheeled Coach	1
		Flash with Primary and Marker lights.	
55-EL-18F3		/-- Front Center ICC Lts: (3) AMBER Weldon LED No 9186-1500A	1
		Switch w/ Headlights.	
55-EL-18F9		/-- Front ICC Lts:(2) Amber Wheeled Coach	1
55-EL-18R9		/-- Rear ICC Lts: (2) Red Wheeled Coach	1
55-EL-18RO		/-- Rear ICC Lts: (3) RED Weldon LED No 9186-1500R	1
		Switch w/ Headlights	
ZZ-ZZ-ZZZZ		/--	1
55-EL-18A5	S	/-- ICC Side Marker Lights Pkg: None	1
55-EL-35A6		/-- Side Marker Lts: (2) Whelen M6 LED Red Running/Turn, ILOS	1
		Running to be wired as Tail and Turn to be wired as Stop.	
		These are to both have flanges.	
55-PH-LF20		/-- M6 Series Flange, Chrome Plated, Std: Each	2
55-EL-2224		/-- Whelen M6 Series, Tail Lights	1
		Whelen M6 Series	
55-EL-2420		/-- Stop/Tail, Whelen M6 Series, LED, Pair	1
		Whelen M6 Series	
55-EL-2426		/-- Turn, Whelen M6 Series, LED, Pair	1
		Whelen M6 Series	
55-EL-2432		/-- Back up, Whelen M6 Series, LED, Pair	1
		Whelen M6 Series	
55-PH-LF21		/-- M6 Series Conversion Flange Pkg: QTY 6	1
		LITE-M6FC600 (6)	



PART NO	S	DESCRIPTION	QTY
55-EL-258N		-- Under Body Lights: None/Leave Existing	1
55-EL-3906		-- Lights, Cab Step: 2" Clear, Mt in box front, LED (TOCACCCR) pair With Chrome Flange Activate by Cab Doors. Constant Hot.	1
55-EL-4304		-- Third (3rd) Brake Light: None On Existing, Do Not Install One	1
55-EL-4564		-- SCENE/FLOOD LIGHTS (LED-M9 Series)	1
55-EL-45B1		-- Scene Light Size: New Lights Same Size, no change	1
55-EL-45L4		-- Left Scene Lights: (2) LED-M9, Whelen	1
06-EL-18LF		-- Left Flood Activate: Left Flood Switch	1
55-EL-0225		-- Flanges: (2) Conversion Flanges for above M9 Scene lights	1
55-EL-45T4		-- Right Scene Lights: (2) LED-M9, Whelen	1
06-EL-18RT		-- Right Flood Activate: Right Flood Switch and open CSE Door	1
55-EL-0225		-- Flanges: (2) Conversion Flanges for above M9 Scene lights	1
55-EL-46R4		-- Rear Load Lights: (2) LED-M9, Whelen	1
05-EL-0226		-- Flanges: (2) Conversion Flanges for above M9 Rear load lights ILOS	1
06-EL-18RE		-- Activate: Rear Flood Switch, Reverse and Lead RA Door	1
56-EL-SDLO		-- Docking Lights: None	1
ZZ-ZZ-ZZZZ		--	1
55-EL-4965		-- Light, Compartment: LED, Intertek #ZY-156-LEDC, Each HEAT AND AC	8
55-HA-0010	S	-- HVAC SYSTEM:	1
05-HB-00F8	S	-- AC (HVAC) SYSTEM:Pro-AIR, - Horizontal T1 Ford	1
05-HA-0406		-- Water Pump: Installed required	1
05-HA-13X6	S	-- Intermotive Module BCVC502A :Installed 2020 +	1
05-HA-14C0		-- AC COMPRESSOR: Tee into OEM	1
05-HA-1600		-- Top of ALS output cover, two vents and fresh air inlet, Laminate over Aluminum	1
05-HB-14PB		-- AC Evaporator: Pro-Air (AC/Heat unit) w/ dual fans - STD horizontal	1
05-HA-1404		-- Heater Hoses: EPDM - Nomex Rubber (per Ford QVM)	1
05-HA-14B5		-- FILTER: Washable Carbon Pre-Filter	1
10-HA-0501	S	-- Thermostat, Rear A/C, Automatic Pro-Air Mini-Digital Thermostat to be same brand as A/C System Located in A/A. See Drawing.	1
55-HA-0400		-- Water Pump: Additional - improve heater performance This pump shall be installed in-line and shall come on with the heat switch position.	1
ZZ-ZZ-ZZZZ		--	1
55-HA-1302	S	-- A/C Condenser	1
05-HB-1325		-- Condenser, 12V: Pro -Air Dual Fan, FRKG 126 under the module body 70,000 BTU	1
04-HA-1300		-- Condenser Brackets: Under M-2, angled down	1
ZZ-ZZ-ZZZZ		--	1
ZZ-ZZ-ZZZZ		--	1
INTERIOR LIGHTING			1
55-IL-0002		-- CEILING PANELS : Leave Existing	1
55-IL-05T0	S	-- Install (1) Techniq Inserts In Existing 18" Fluorescent Housing Techniq E39-M000-1	3
55-IL-0608		-- Timer: Electronic, 15 Min with momentary switch Located on curbside wall at head of squad bench. TIME-VCM15	1
06-EC-09P1		-- Timer to Power: Street side DOMES, High intensity	1
ZZ-ZZ-ZZZZ		--	1
59-MH-0800		-- IV Hooks : Leave Existing	1





PART NO	S	DESCRIPTION	QTY
06-EC-0505		-- Door Locks, Tied into OEM System Module power locks are tied to the Chassis power lock system	7
06-EC-0512		-- OEM Key Fob: Included w/Chassis Unlock Mod Doors Must also operate the Module Power Door Locks Optioned.	7
06-EC-05C9		-- Door Lock Switches : Integrated in Interior Entry door Handles	7
06-EC-05K0		-- ONLY the following doors shall have power door locks:	7
06-EC-05M1		-- Electric Door Lock: (M-1) Left Front Compartment	7
06-EC-05M2		-- Electric Door Lock: (M-2) Left Middle Compartment	7
06-EC-05M4		-- Electric Door Lock: (M-3) Left Rear Compartment	7
06-EC-05M6		-- Electric Door Lock: Rear Access Doors	7
06-EC-05M7		-- Electric Door Lock: (M-5) Right Rear Compartment	7
06-EC-05M9		-- Electric Door Lock: (M-6) Right Rear, Forward Compt	7
06-EC-05N0		-- Electric Door Lock: Curbside Access Door	7
06-EC-05N1		-- Electric Door Lock: (M-7) Right Front Compt	7
56-10-0050		-- Patient on board lights not required, leave existing	1
56-10-00SW		-- Hidden Unlock Switches	1
56-EC-2800		-- Door Unlock Switch, Momentary, Exterior, hidden	1
NOTE: Installation of Remote Door Lock Switch feature may increase likelihood of unauthorized entry into vehicle. By checking this option, purchaser further agrees to hold REV or chassis manufacturer harmless for any loss of vehicle or contents caused by unlawful access.			
06-EC-0802		-- Location: Front Grille/Bumper Area	1
ZZ-ZZ-ZZZZ		--	1
56-1E-0002		-- Install (2) Blower Exhaust Fans, Front and Rear Part #:BLOW-03	1
56-AA-0210		-- Flasher, Headlight: NONE	1
56-AL-47NO		-- Hand Held Spot Light: NONE	1
ZZ-ZZ-ZZZZ		--	1
ZZ-ZZ-ZZZZ		--	1
<b>BATTERIES :</b>			
56-BA-3F42		-- Batteries: 3 - Battery System - Type I Only	7
06-BA-3F57		-- Batteries: (3) Batteries, ILOS Type I Diesel	7
06-BA-3F61		-- Batteries: (2) Under hood, (1) in M8 Cmp	7
06-BA-3FJ3		-- Battery Make: (2) OEM, (1) Random Make Battery Brand must match.	7
56-BA-Q630	S	-- Battery Switch: Cole Hersee 2484-16 Paddle, Replace with NEW Cole Hersee Paddle style battery switch powers up and shuts down the CONVERSION only! Chassis related circuits shall remain wired in the O.E.M. configuration per Ford QVM Bulletin No 63. LOCATION: Driver side seat base With Face Plate LABEL	7
ZZ-ZZ-ZZZZ		--	7
56-BA-0020		-- Additional Module Batteries NONE	1
56-BA-35NO		-- Battery Tray: NONE	1
56-BA-3FD2		-- Battery Make: OEM per chassis Batteries OEM as provided with Chassis spec.	1
56-BA-3HSW		-- Round Monmentary Ignition Timer Switch: NONE	1
ZZ-ZZ-ZZZZ		--	1
56-EC-3059	S	-- Install OEM Back Up Camera	7
56-EC-30CN		-- Monitor Mount: None	1
ZZ-ZZ-ZZZZ		--	1
56-EC-3501		-- Circuit Board: Leave Existing	1
56-RR-F3H2	S	-- Console: Custom Metal Console Custom Console	7

PART NO	S	DESCRIPTION	QTY
56-EC-4300		-- Standard Back-up Alarm: Install New	1
06-EC-43B0		-- Cut Off Switch: Auto reset ,momentary style	1
11-ZZ-0933		-- CAAS GVS V2.0 Exception C.16.1 Reset of Back-up Alarm	1
		Installation of a reset of a back-up alarm shall cause an exception to the GVS 2.0 Standard for C.16.1 for this instance when a vehicle is shifted into reverse.	16.1
ZZ-ZZ-ZZZZ		--	1
56-EL-SDL0		-- Docking Lights: None	1
ZZ-ZZ-ZZZZ		--	1
		<b>INVERTERS AND GENERATORS</b>	1
56-IG-00LE		-- INVERTER : Leave Existing Model	1
56-IG-BB00		-- Leave Existing Breaker Box and Breakers	1
56-IG-G001		-- GENERATOR: None/ Leave Existing	1
ZZ-ZZ-ZZZZ		--	1
		<b>COMMUNICATION RADIO(S) RELATED</b>	1
		ALL radio components must be removed from cab area prior to shipment to REV.	
56-RR-1809		-- Patient Area Radio : None	1
		<b>125V SHORE LINE AND OUTLETS</b>	1
56-SO-0500	S	-- Shore Line Inlet: 20A Super Auto Eject, Replacement Reinstall Existing Indicator Panel	1
06-SO-00L1		-- Inlet location: Aft of Left Front compartment	1
06-SO-1005		-- Cover, Yellow, Shore Line Inlet : 20A Super Auto Eject, STD	1
ZZ-ZZ-ZZZZ		--	1
56-SO-10TT		-- Inpower Timer: VCM-05-01SF, Installed	1
		NOTE: This allows the auto eject to be wired to the ignition switch ILO splicing into the OEM starter circuit and is required any this vehicle	
56-SO-00A3		-- Additional Shoreline: None	1
ZZ-ZZ-ZZZZ		--	1
56-SO-1100		-- **INTERIOR 12 Volt OUTLETS**	1
56-SO-112U	S	-- 12V Outlets, (2) Triple Receptacle 12V AND (1) DOUBLE USB INSTALL 1 IN CONSOLE 1 IN AA 1 IN ALS 1 ON SQUAD BENCH WALL	4
ZZ-ZZ-ZZZZ		--	4
56-SO-11LE		-- 12V Outlets : Leave Existing Outlets	1
ZZ-ZZ-ZZZZ		--	1
56-SO-1400		-- **125 Volt OUTLETS**	1
56-SO-14LE		-- 125 VAC Outlets : Leave Existing Outlets	1
		All 125 VAC outlets shall be back lighted when power is applied to the outlet.	
ZZ-ZZ-ZZZZ		--	1
		<b>SIRENS AND SPEAKERS</b>	1
56-SS-062F	S	-- Siren: Whelen, WS295HFSA7, F-Series	1
56-SS-DF00	S	-- Siren Speakers: Federal # ES100-ESMFT-EF, Ford F-350/450/550 2017 ILOS These speakers require a recessed mount requiring a hole in the outer end of the front bumper. Federal siren speakers may not be covered under warranty unless paired with Federal sirens.	1
56-SS-SW01		-- Siren / Horn Switch: In Cab Console This switch shall select horn ring output. Siren Functions OR O.E.M. Horn	1
56-SS-1340		-- Air Horn System: Remove and Install on new chassis Remove air horn system from old chassis and install on new chassis	1

PART NO	S	DESCRIPTION	QTY
56-SS-132A		/-- Air Horn: 10" Strombos Horn, Chrome, No 1061 (493 Hz)	7
56-SS-132B		/-- Air Horn: 12" Strombos Horn, Chrome, No 1062 (396 Hz)	7
56-SS-G000		-- Insulation for Siren Speakers: None/Leave Existing	1
ZZ-ZZ-ZZZZ		--	1
ZZ-ZZ-ZZZY		--	1
ZZ-ZZ-ZZZZ		--	1
<b>CABINET SHOP - Modular</b>			
57-00-HO00		-- Door Hold Gas Shocks: Leave Existing	1
57-00-PC02	S	/-- Lexan Windows - GRAY, Replace, Per Opening Replace Lexan Windows & Handles	7
07-00-PH01		/-- Window Handles: Full Length Extruded	7
07-00-PS01	S	/-- Security Tag Holes: NONE	7
ZZ-ZZ-ZZZZ	S	/--	7
57-AC-0000		-- Air Conditioning Cabinet : Leave Existing	1
ZZ-ZZ-ZZZZ		--	1
57-AT-0020		/-- ATTENDANT SEAT BASE: Replace with New Base - Swivel Pedestal	7
57-BH-0000		-- Bulkhead Cabinet : Leave Existing	1
ZZ-ZZ-ZZZZ		--	1
57-CA-0000		-- Curbside Upper Cabinet : Leave Existing	1
ZZ-ZZ-ZZZZ		--	1
57-CA-4798		-- Solid Surface Trays: None	1
57-CR-0000		-- Curbside Rear Cabinet : Leave Existing	1
ZZ-ZZ-ZZZZ		--	1
57-CS-0000	S	/-- Curb Side Wall Panel- Replace Existing With New Panel	7
ZZ-ZZ-ZZZY		/--	7
57-LF-0000		-- Left Front Cabinet : Leave Existing	1
ZZ-ZZ-ZZZZ		--	1
57-RF-0000		-- Right Front (ALS) Cabinet : Leave Existing	1
57-CA-4400		/-- Cargo Net, 2" Webbing, On Cabinet	7
ZZ-ZZ-ZZZZ		--	1
57-SB-0000		-- Squad Bench Cabinet : Leave Existing	1
ZZ-ZZ-ZZZZ		--	1
57-TC-0000		-- Top Cabinet : Leave Existing	1
ZZ-ZZ-ZZZZ		--	1
57-WC-0000		-- Wall Cabinet : Leave Existing	1
ZZ-ZZ-ZZZZ		--	1
ZZ-ZZ-ZZZY		--	1
ZZ-ZZ-ZZZZ		--	1
<b>CABINET SET - Station No 4 - MOD</b>			
57-01-SEF9		/-- Attendant Seat EVS 1880 10 degree Back 4pt Seat Belt with Child seat 4pt	7
57-01-SEFA	S	/-- Att Seat, EVS # 1880 W/ 4-pt Belt, Child Safety Seat, Vac form Gunmetal ILOS 4 point belt color: Black SEAT-E18804VG	7
11-SE-04A0		/-- Attendant Seat, Armrest: None	7
57-SE-0901		/-- BASE: Swivel base for EVS Child Seat Option (2) Position Swivel, Forward or Rearward, Only BASE-1882S	7
ZZ-ZZ-ZZZZ		/--	7
58-00-FL50		/-- Flooring: Tarkett Optima - Dark Gray Sidewalk 05-866	7
58-00-FL01		/-- Flooring Main Edge: 3" Recessed (1/2" deep) roll-up	7
ZZ-ZZ-ZZZZ		/--	7
58-CS-0001		-- COT MOUNT HARDWARE: (Full Size Mod)	1
58-CR-09PP	S	/-- Cot Mount: Stryker, No 6390, Power Load, Prep ONLY >>NON COMPLIANT << This will have everything needed for Customer/Dealer to install the Stryker system at a later date. Constant hot and ground service power provided. Prep will include, installation of Floor Plate Kit	1

PART NO	S	DESCRIPTION	QTY
		THIS DOES NOT INCLUDE ANY COT MOUNT >>>>> EXCEPTION TO 3.11.6 >> THIS is an incomplete installation, an exception is required, COMPLIANT installation.	NON
08-CR-1005		-- Power connection left coiled under module for Power load	1
08-CS-3009		-- Cot mount set up for: Stryker Power-Pro 6506	1
58-CR-09PZ		-- No Additional Mass Casualty Cot Mount	1
58-CS-00PL		-- Cot Position No 1: PRIMARY CENTER POSITION, Maintain 12" between Cot and S/B	1
ZZ-ZZ-ZZZZ	S	-- Install 1 Strker Floor Plate for Release Bar	1
58-CS-19U1		-- Q Straint System: NONE	1
58-OS-04ST		-- OXYGEN / AIR / VACUUM SYSTEM :	1
58-OS-03LE		-- Oxygen Outlets : Leave Existing	1
08-ZZ-ZZZZ		--	1
58-OS-13LE	S	-- Cylinder Rack:	1
08-OS-13SQ	S	-- Rack No 1:M cylinder, (2) Steel rings Yellow ILOS (Install Steel rings and neck bracket) powder coated yellow.	1
08-OS-11G1		-- Cylinder Type: OXYGEN - Green Colored Hose Regulator connection Nut: 9/16" RH thread.	1
08-OS-1301	S	-- Rack Location: M1 Compartment	1
08-OS-132M		-- Set up For M cylinder	1
08-OS-1902		-- Regulator Wrench: Cast aluminum, OXYGEN w/ cable lanyard	1
ZZ-ZZ-ZZZZ		--	1
58-OS-3500		-- Collection Canister: Bemis 1200 CC Capacity Replace with new Holder and canister SSCOR 23002	1
58-OS-35NO		-- Vacuum Pump: None/Leave Existing	1
58-SE-SB0L		-- Seat Belt System - Replace Existing with New	1
58-SE-SB06	S	-- 2pt Belt, Replace Existing with New (specify qty) BELT-2611S	3
58-SE-SB67		-- Seat Belt: Female Buckle, 8" Sleeve, Replace Existing with New	3
ZZ-ZZ-ZZZY		--	1
ZZ-ZZ-ZZZZ		--	1
		<b>TRIM / DOOR ASSEMBLY - Station No 5</b>	
59-AS-0000		-- Stainless Rear Threshold : Leave Existing	1
59-AS-0100		-- Entry Door Panels : Leave Existing	1
ZZ-ZZ-ZZZZ		--	1
59-B1-ED00		-- Entry Door Panels, Windows and Hardware	1
58-MH-0300		-- Grab Handle, CS Entry: Leave Existing	1
58-MH-0302		-- Grab Handle, Rear Entry: Leave Existing	1
59-BT-D001	S	-- Nader Pin Guards, Lower Rear Entry Doors Both Rear Entry Doors Only, Bottom Pins only	1
59-FM-1093		-- Dri-Dek Compartment Floors, Black	1
ZZ-ZZ-ZZZZ		--	1
59-MH-253N		-- Rear Entry Assist Handle not required	1
59-MH-2702		-- Grab Rail, C/S wall, curve out over C/S Entry, NONE	1
58-MH-1400		-- Restraint Net, Black, 7 point detachable, at head of S/B, Mod Seven (7) NET Attachment Points: Black in color. NETS-MOD2	1
ZZ-ZZ-ZZZZ		--	1
ZZ-ZZ-ZZZZ		--	1

PART NO	S	DESCRIPTION	QTY
ZZ-ZZ-ZZZZ		--	1
59-RR-70NO		-- Speakers, Stereo: NONE	1
		<b>WINDOWS</b>	
59-WI-0001		-- C/S Door Windows : Leave Existing Inspect & replace window gasket, as needed. Perform water test to verify windows are sealed correctly	1
ZZ-ZZ-ZZZZ		--	1
59-WI-0002		-- Rear Access Door Windows : Leave Existing Inspect & replace window gasket, as needed. Perform water test to verify windows are sealed correctly	1
ZZ-ZZ-ZZZZ		--	1
ZZ-ZZ-ZZZZ		--	1
ZZ-ZZ-ZZZY		--	1
ZZ-ZZ-ZZZZ		--	1
		<b>ELECTRICAL Point to Point - Station No 6</b>	
60-EC-1390		-- IV Warmer No 1: NONE	1
60-SW-A100		-- Switch Panel: Action Area - Replace with New	1
ZZ-ZZ-ZZZZ		--	1
60-EC-REFR		-- Refrigerator: Leave Existing or None	1
ZZ-ZZ-ZZZY		--	1
ZZ-ZZ-ZZZZ		--	1
		<b>UPHOLSTERY - Station No 7</b>	
61-00-LIC01		-- <b>Upholstery Color: Dark Gray (Gunmetal) Vac Form</b> Replace all cushions, pads and trim	1
ZZ-ZZ-ZZZZ		--	1
09-DR-WT00	S	-- <b>Talk Through Window: Clear Sliding window</b>	1
ZZ-ZZ-ZZZZ		--	1
		<b>PAINT - STRIPES - DECALS</b>	
62-00-01NO		-- Window Tint: None	1
62-DC-0001		-- Reflective Tape: On painted edges of Exterior Door Frame	1
62-DC-0002		-- Flip Step Reflective/Prismatic Tape: Red/White/R/W/R/W/R Install on rearward facing edge of flip up step at rear module entry.	1
62-PT-0100	S	-- <b>Primary (Over All) Color: Ford White (YZ)</b>	1
62-PT-4999		-- <b>Cab Paint : None, OEM White</b> <b>Cab is not repainted</b>	1
62-PT-DRIP		-- <b>Drip Rails: Installed Bright Aluminum, De-burred and rounded corners</b> <b>Include a drip rail over the C/S Entry Door.</b>	1
ZZ-ZZ-ZZZZ		--	1
62-PT-0600		-- Paint Belt: NONE	1
62-PT-1000		-- Pin Stripe: NONE	1
12-ZZ-ZZZZ		--	1
62-PT-1301		-- Special Striping: Chevron Items: NONE	1
62-PT-2000		-- Lettering: NONE	1
12-ZZ-ZZZZ		--	1
ZZ-ZZ-ZZZZ		--	1
		<b>DETAIL - SHIP LOOSE ITEMS</b>	
63-KK-KDED		-- Decals: KKK / DOT Pkg, - NONE	1
ZZ-ZZ-ZZZZ		--	1
63-KK-NSSB		-- Decals: NO SMOKING & SEATBELT, installed, cab & pt. area.	1
ZZ-ZZ-ZZZZ		--	1
63-MH-10A0		-- <b>Reflector Pkg: Body - 2ea, Side Fr Amber, Side Re Red, Rear</b> Stick-on reflectors: Peterson "Spitfire" B484R and B484A LOCATIONS: In lower corners of module	1



PART NO	S	DESCRIPTION	QTY
		(2) - (1) each side and Front - AMBER	
		(2) - (1) each side and Rear - RED	
		(2) - On Rear of body - RED	
<b>ZZ-ZZ-ZZZZ</b>		/--	
63-RF-STAD		-- Decals: Star of Life for Mod Roof - NONE	1
<b>ZZ-ZZ-ZZZZ</b>		--	1
		<b>== Remount, Base - 20.001 06/28/21 ==</b>	1
		<b>GENERAL CONVERSION</b>	1
50-30-1952		<b>REV Brand Remount</b>	1
50-30-1959		-- REV Basic Conversion	1
		New 1875 FMVSS 206 Door Hardware Keep existing Electrical System	1
50-30-2135		-- CONVERSION ONLY: REV Basic Type 1 Same Chassis 18-1	1
<b>ZZ-ZZ-ZZZZ</b>		--	1
51-CD-0060		<b>Chassis Disposal : Chassis Held for Customer Pick Up</b>	1
		Note : After (60) days from chassis drop-off, \$20 per day storage fee will be applied.	
ZZ-50-REM0		REV REMOUNT NOTICE	1
		The above quote is based on information and photos supplied to the REV Solutions Center. Upon receipt of the unit at the REV Solutions Center an inspection will be performed. At times items may not be identified until the unit is in the production process. If items are identified as not operational or not to the standards our customers expect, the REV Solutions Center will notify the Dealer/Customer of those items and provide a quote to correct them offering the opportunity to make the suggested changes. Unfortunately some of these items cannot be identified until we start the remount process.	

## **Agenda Request – Jasper County BOC**

**Department:** Board of Commissioners

**Date:** November 1, 2021

**Subject:** 2021 Capital Improvements Element Annual Update

### **Summary:**

A Work Session was held on October 25, 2021 to review and discuss updates to the 2020 CIE Reports.

Staff has incorporated the changes and prepared for Board review a preliminary draft of an annual update to the Capital Improvements Element and Short Term Work Program for FY 2021 in accordance with the Development Impact Fee Compliance Requirements established by the Georgia Department of Community Affairs.

### **Background:**

The Georgia Department of Community Affairs requires Counties that participate in the Impact Fee Program to submit an annual update of the Capital Improvements Element and Short Term Work Program. NEGRC provides an initial review and then submits to the DCA for State review.

### **Cost:**

### **Recommended Motion:**

Board Discretion



Jasper County Board of Commissioners  
 Report of Accomplishments  
 Impact Fees  
 Capital Improvements Project Update  
 FY 2017 - 2021

Actual Cost of							
Project Description	Start Date	End Date	Project	Funding Sources	Funding Percentage	Status/Remarks	
<b>Library</b>							
Circulation Materials	7/1/2016	6/30/2017	14,604.00	Impact Fees	100%	Uncle Remus Regional Library System	
Circulation Materials	7/1/2018	6/30/2019	19,051.81	Impact Fees	100%	Uncle Remus Regional Library System	
Circulation Materials	7/1/2019	6/30/2020	6,483.34	Impact Fees	100%	Azalea Regional Library System	
<b>Library Total</b>			<b>40,139.15</b>				
<b>Parks &amp; Recreation</b>							
<b>Parks &amp; Recreation Total</b>							
<b>Fire</b>							
Command, Rescue and ALS Response Vehicle	7/1/2016	6/30/2017	29,915.00	Impact Fees	100%	Support Fire Rescue	
New 911 Tower Antennas & Equipment	7/1/2017	6/30/2018	5,868.91	Impact Fees	100%	Support 911 Communication	
New Lucas Devices and Extrication Equipment	7/1/2019	6/30/2020	46,531.04	Impact Fees	100%	Support Fire Rescue	
<b>Fire Total</b>			<b>82,314.95</b>				
<b>Jail</b>							
<b>Jail Total</b>							
<b>Sheriff</b>							
<b>Sheriff Total</b>							
<b>E-911</b>							
New 911 Tower Antennas & Equipment	7/1/2017	6/30/2018	5,285.60	Impact Fees	100%	Improve 911 Communication	
NexGen Compliant Telephone System	7/1/2020	6/30/2021	84,000.00	Impact Fees	100%	Additional Communication Capability	
<b>E-911 Total</b>			<b>89,285.60</b>				
<b>Admin</b>							
Surface Pro Tablets; BOC Meeting Room	7/1/2019	6/30/2020	9,572.91	Impact Fees	100%	Improve BOC Meeting Communication	
Install Credit Card Capability	7/1/2020	6/30/2021	121.72	Impact Fees	100%	Improve Taxpayer Pay Ability	
<b>Admin Total</b>			<b>9,694.63</b>				
<b>Report of Accomplishments Total</b>			<b>221,434.33</b>				

**Jasper County Board of Commissioners - Impact Fee Capital Improvement Project List  
FY 2022 - 2026**

Public Facility	Service Area	Project Start Date	Project End Date	Estimated Cost of Project	Responsible Parties	Funding Sources	Funding Percentage	Project Description	Status/Remarks
Library	County Wide	2022	2026	28,872	Jasper County BOC, Uncle Remus Library Board	Impact Fees	100%	Books, Circulation Materials	
Parks & Recreation	County Wide	2021	2023	267,583	Jasper County BOC	Impact Fees	100%	Multi-Purpose Building, Multi-Use Recreation Fields	
Fire	County Wide	2022	2026	289,287	Jasper County BOC	Impact Fees	100%	Fire Station, Fire Fighting Equipment, Emergency Safety Equipment, Extrication Equipment	
Jail	County Wide	2021	2022	190,942	Jasper County BOC	Impact Fees	100%	Jail Confinement Expansion and Addition, Security Automation	
Sheriff	County Wide	2021	2022	247,099	Jasper County BOC	Impact Fees	100%	Sheriff Office Administration Renovation and Expansion	
E911	County Wide	2021	2022	118,175	Jasper County BOC	Impact Fees	100%	Radio Communication Relocation and Upgrades	
Administration	County Wide	2022	2026	25,660	Jasper County BOC	Impact Fees	100%	Administrative Equipment, Computers, Monitors	
				1,167,618					

**Jasper County Board of Commissioners**  
**Short Term Work Program – Jasper County, GA**  
**Countywide**  
**FY 2022 - 2026**

Plan Element	Project Description	FY Year Initiated	Projected FY Year of Completion	Cost Estimate	Responsible Party	Funding Source	Notes
Community Facilities	Perform water and sewer facility upgrades and replacements, and provide extensions to planned developments.	2017	2026	\$5,000,000	Water & Sewer Authorities	CDBG, GEFA, USDA, Local	
Community Facilities	Continue to provide private curbside collection of solid waste.	2017	2026	\$776,000 Annually	BOC, Monticello City Council	User Fees	Continuing
Community Facilities	Increase public education and awareness regarding recycling and waste reduction.	2017	2026	\$12,000 Annually	BOC, Shady Dale City Council	Local / State	Clean Up Jasper Campaign
Community Facilities	Construct new Recreation Multi-purpose Facility	2020	2023	TBD	BOC	SPLOST, Grants, Impact Fees, Local	Splost Referendum November 2017
Community Facilities	Implement Recreation improvement projects based on County and Cities' parks and recreation plans	2017	2023	Project Dependent	BOC, Monticello City Council, Shady Dale City Council	SPLOST, DNR, DCA, Local	Continuing
Community Facilities	Addition and Renovation to Sheriff's Administrative Office Space	2021	2022	\$3.6M	BOC	SPLOST, Grants, Impact Fees, Local	Splost Referendum November 2017
Community Facilities	Jail Confinement Expansion and Addition, Security Automation	2021	2022	\$3.0M	BOC	SPLOST, Grants, Impact Fees, Local	Splost Referendum November 2017
Community Facilities	Vehicle Rotation Plan for structured replacement of Sheriff's Patrol Vehicles	2014	2026	Varies with lease, cash purchase program	BOC	SPLOST, Local	Continuing
Community Facilities	New Generator - Jail, Sheriff's Office, 911 Center, Fuel Pumps; Relocate Existin Generator	2021	2022	\$77,000	BOC	SPLOST, Local	Add New; Relocate Existing
Community Facilities	Pave and repair roads annually to include utilization of outside contractors as well as County PW staff.	2017	2026	\$1,000,000 Annually	BOC	LMIG, SPLOST, Local	Increased Use of PW Chip Seal Equipment
Community Facilities	Procure Roads and Bridges Reclamation, Renovation & Maintenance equipment	2018	2026	Based on specific equipment	BOC, Monticello City Council, Shady Dale City Council	SPLOST, Local	New Tree Limbing Tractor, New Skid Steer
Community Facilities	Fire Stations, Fire Rescue Equipment Replacement Plan - Ambulances, Engines, Tankers, Safety Equipment	2017	2026	Based on specific project	BOC	SPLOST, Impact Fees, Local	New Ambulance Planned for 2021
Community Facilities	Radio Communication Relocation	2020	2022	Based on specific project	BOC	SPLOST, Impact Fees, Local	
Community Facilities	Implement Disaster Preparedness Plan that addresses Continuity of Operations and Operational Redundancy	2018	2026	\$0	BOC	N/A	Continuing
Community Facilities	Develop IGA's with Municipal Governments for improvements and efficiencies	2017	2026	\$0	BOC, Monticello City Council, Shady Dale City Council, and Other surrounding county BOC's	N/A	Code Enforcement
Community Facilities	Review and update Jasper County's Code of Ordinances	2020	2026	To be Determined	BOC	Local	Continuing

Plan Element	Project Description	FY Year Initiated	Projected FY Year of Completion	Cost Estimate	Responsible Party	Funding Source	Notes
Community Facilities	Become a designated Broadband Ready Community	2020	2026	To be Determined	BOC, Monticello City Council, Shady Dale City Council, COC, Development Authority of Jasper County, Four County Development Authority, DCA, NEGRC	Local, State and Federal	
Community Facilities	Community Resource Center (Food Bank)	2021	2022	Approximately \$750K	BOC, Health Department, Chamber of Commerce, Senior Center	Local, State and Federal, CDBG Grant	Received 2021 CDBG Award
Community Facilities	Landfill Equipment Compactor, Excavator, Bulldozer	2022	2026	TBD	BOC, Grants	BOC, Grants	Analyzing Priority
Community Facilities	Animal Shelter Incinerator	2022	2022	TBD	BOC, Grants	BOC, Grants	
Economic Development	Promote job-training efforts from local and regional sources	2017	2026	Varies Annually	Development Authority of Jasper County, Board of Education, Downtown Development Authority, Piedmont & Shiloh Academy	Local, State and Federal	Continuing
Economic Development	Foster cooperative relationship among local government entities, EDA, DDA, SCTC, the COC, the BOE, and private businesses and schools to monitor labor force conditions and needs.	2017	2026	\$0	Chamber of Commerce, DDA, DAJC	N/A	Continuing
Economic Development	Study local economic characteristics and conditions to address potential for economic diversification.	2017	2026	Development Authority of Jasper County Budget	DDA, DAJC	Development Authority of Jasper County Budget	Continuing
Economic Development	Participate in multi-jurisdictional regional tourism planning efforts	2017	2026	Chamber of Commerce Budget, Development Authority of Jasper County Budget, Downtown Development Authority Budget	Chamber of Commerce, Development Authority of Jasper County, Downtown Development Authority	Chamber of Commerce Budget, Development Authority of Jasper County Budget, Downtown Development Authority Budget	Continuing
Economic Development	Utilize the Future Land Use map to coordinate new economic development in appropriate area serviced by necessary facilities and services	2017	2026	\$0	Development Authority of Jasper County, Downtown Development Authority, United States Forest Service, Department of Natural Resources	N/A	Continuing
Economic Development	Actively promote and market Jasper County's economic resources through various state agencies and interstate clearinghouses	2017	2026	Chamber of Commerce Budget	Chamber of Commerce, DDA, DAJC	N/A	Continuing

Plan Element	Project Description	FY Year Initiated	Projected FY Year of Completion	Cost Estimate	Responsible Party	Funding Source	Notes
Economic Development	Seek ways to reduce the amount of retail dollars spent outside the county.	2017	2026	Chamber of Commerce Budget, Downtown Development Authority Budget, Development Authority of Jasper County Budget	Chamber of Commerce, Downtown Development Authority, Development Authority of Jasper County	Chamber of Commerce Budget, Downtown Development Authority Budget, Development Authority of Jasper County Budget	Continuing
Economic Development	Continue to invest in regional economic development initiatives.	2017	2026	Varies	BOC, Monticello City Council, Shady Dale City Council, Development Authority of Jasper County, Four County Development Authority	Local	Continuing
Economic Development	Create additional Industrial Parks as needed to support Economic Development Efforts	2017	2026	Varies according to project	Development Authority of Jasper County	State, Federal	
Housing	Encourage residential development that conserves open space and sustains rural character in accordance with the Future Land Use Plan.	2017	2026	\$0	Local, Planning & Zoning	N/A	
Housing	Host a housing fair with available resources from various organizations, realtors, banks and others	2020	2026	To be Determined	BOC, Monticello City Council, Shady Dale City Council, Housing Authority, DCA	Local	
Housing	Develop a strategic plan to work with neighborhood groups to monitor, improve, support and maintain existing neighborhoods.	2020	2026	\$0	BOC, Monticello City Council, Shady Dale City Council, DAJC, Neighborhood Groups	N/A	
Land Use	Utilize the Future Land Use Map to coordinate new development with the Comprehensive Plan.	2017	2026	\$0	Local	N/A	
Land Use	Address the Future Land Use Map every two years to ensure it reflects prevailing development patterns.	2017	2026	\$0	Local	N/A	Continuing
Natural & Cultural Resources	Actively promote the countywide tourism Plan thru marketing materials	2017	2026	Chamber of Commerce Budget	Chamber of Commerce	Local	Continuing
Natural & Cultural Resources	Promote the Countywide greenways/trails plan	2020	2026	To be Determined	BOC, Monticello City Council, Shady Dale City Council, DAJC, Neighborhood Groups	Local, DNR	



## **Agenda Request – Jasper County BOC**

**Department:** Finance Department

**Date:** November 1, 2021

**Subject:** Open New Bank Account for the Food Bank - 2021 CDBG Grant

### **Summary:**

Finance requests to open a new bank account to be used specifically for receiving and disbursing the 2021 CDBG Grant proceeds.

### **Background:**

The Department of Community Affairs requires a non-interest bearing bank account be established to receive the drawdown of funds from the CDBG Grant. This bank account will be utilized to pay vendor invoices approved and administered by the Northeast Georgia Regional Commission.

The Jasper County 2019 CDBG Grant was banked with Bank of Monticello. Management proposes to bank the Jasper County 2021 CDBG Grant with Bank of Monticello.

### **Cost:**

N/A

### **Recommended Motion:**

Authorize Chairman to sign the Bank of Monticello new account agreement.

**New Business –Item**

**Agenda Request – Jasper County BOC**

Department: Finance

Date: November 1, 2021

Subject: FY 2022 1<sup>st</sup> Quarter Financial Report

**Summary:**

Staff will present a Financial Report for 1<sup>st</sup> Quarter FY2022.

**Background:**

**Cost:**

None

**Recommended Motion:**

None Required

JASPER COUNTY BOARD OF COMMISSIONERS  
 FY2022 1ST QUARTER  
 FINANCIAL REPORT  
 JUNE 30, 2022

FUND #		FY 2022 BUDGET	FY 2022 ACTUAL	% COLLECTED	% REMAINING
100	GENERAL FUND -				
<u>LINE #</u>	<u>REVENUE</u>				
1	ADVALOREM PROPERTY TAX	\$ 6,361,190	\$ 2,477,053	38.9%	61.1%
2	VEHICLE & MOBILE HOME TAX	\$ 1,028,091	\$ 199,204	19.4%	80.6%
3	PRIOR YEARS TAX	\$ 291,000	\$ 78,037	26.8%	73.2%
4	FOREST LAND PROTECTION GRANT	\$ 470,778	\$ -	0.0%	100.0%
5	LOCAL OPTION SALES TAX	\$ 875,000	\$ 180,623	20.6%	79.4%
6	INSURANCE PREMIUM TAX	\$ 828,000	\$ -	0.0%	100.0%
7	TAX COMISSIONER COMMISSION	\$ 235,000	\$ 87,088	37.1%	62.9%
8	TIMBER TAX	\$ 50,000	\$ 7,669	15.3%	84.7%
9	RAILROAD TAX	\$ 33,000	\$ -	0.0%	100.0%
10	REAL ESTATE TRANFER TAX	\$ 64,000	\$ 18,258	28.5%	71.5%
11	INTANGIBLE TAX	\$ 190,000	\$ 68,360	36.0%	64.0%
12	ALCOHOL EXCISE TAX	\$ 65,000	\$ 10,583	16.3%	83.7%
13	BUSINESS LICENSE TAX	\$ 25,000	\$ -	0.0%	100.0%
14	ENERGY EXCISE TAX	\$ 4,500	\$ 2,341	52.0%	48.0%
15	SPECIAL DIGEST - STANTON SPRINGS	\$ -	\$ -		
16	OTHER TAXES	\$ 750	\$ 103	13.7%	86.3%
17	PENALTIES & INTEREST	\$ 117,000	\$ 27,059	23.1%	76.9%
18	EMS	\$ 340,000	\$ 93,794	27.6%	72.4%
19	PROBATE COURT	\$ 165,000	\$ 38,745	23.5%	76.5%
20	SUPERIOR COURT	\$ 190,000	\$ 53,485	28.1%	71.9%
21	SHERIFF	\$ 39,000	\$ -	0.0%	100.0%
22	JAIL	\$ 8,500	\$ 4,068	47.9%	52.1%
23	RECREATION	\$ 48,000	\$ 2,449	5.1%	94.9%
24	PLANNING & ZONING	\$ 177,400	\$ 46,725	26.3%	73.7%
25	EMA	\$ 7,355	\$ -	0.0%	100.0%
26	ANIMAL CONTROL	\$ 5,550	\$ 220	4.0%	96.0%
27	FIRE DISTRICT - JCWSA	\$ 48,000	\$ 15,433	32.2%	67.8%
28	CARES GRANT	\$ -	\$ -		
29	FOREST WILDLIFE GRANT	\$ 30,000	\$ -	0.0%	100.0%
30	INTEREST	\$ 14,000	\$ 1,469	10.5%	89.5%
31	FAMILY CONNECTION GRANT	\$ -	\$ -		
32	OTHER REVENUE	\$ -	\$ 18,846		
33	SENIOR CENTER	\$ 159,500	\$ 23,646	14.8%	85.2%
34	TOTAL GENERAL FUND REVENUE	\$ 11,870,614	\$ 3,455,257	29.1%	70.9%

100	GENERAL FUND -	FY 2022 BUDGET	FY 2022 ACTUAL	% EXPENDED	% UNENCUMBERED
<u>DEPT #</u>	<u>EXPENDITURES</u>				
35	100 GENERAL GOVERNMENT	\$ 2,041,632	\$ 441,289	21.6%	78.4%
36	200 JUDICIAL	\$ 930,023	\$ 193,521	20.8%	79.2%
37	300 PUBLIC SAFETY	\$ 5,160,977	\$ 1,020,045	19.8%	80.2%
38	400 PUBLIC WORKS	\$ 2,007,719	\$ 445,584	22.2%	77.8%
39	600 CULTURE/RECREATION	\$ 547,208	\$ 116,462	21.3%	78.7%
40	700 HOUSING & DEVELOPMENT	\$ 327,910	\$ 72,819	22.2%	77.8%
41	900 APPROPRIATIONS	\$ 349,354	\$ 78,009	22.3%	77.7%
42	950 COMPONENT UNITS	\$ 673,423	\$ 168,356	25.0%	75.0%
43	900 CAPITAL TRANSFER	\$ -	\$ -		
44	TOTAL GENERAL FUND EXPENDITURES	\$ 12,038,246	\$ 2,536,085	21.1%	78.9%

JASPER COUNTY BOARD OF COMMISSIONERS  
 FY2022 1ST QUARTER  
 FINANCIAL REPORT  
 JUNE 30, 2022

LINE #	DEPT #	EXPENDITURES	FY 2022 BUDGET	FY 2022 ACTUAL	% EXPENDED	% UNENCUMBERED
	100	GENERAL FUND -				
	100	GENERAL GOVERNMENT-				
45	01110	BOARD OF COMMISSIONERS	\$ 263,749	\$ 72,012	27.3%	72.7%
46	01300	EXECUTIVE	\$ 205,750	\$ 43,251	21.0%	79.0%
47	01400	ELECTIONS	\$ 30,779	\$ 1,990	6.5%	93.5%
48	01401	REGISTRAR	\$ 69,137	\$ 15,313	22.1%	77.9%
49	01510	FINANCIAL ADMINISTRATION	\$ 199,523	\$ 29,024	14.5%	85.5%
50	01540	HUMAN RESOURCES	\$ 104,650	\$ 12,888	12.3%	87.7%
51	01545	TAX COMMISSIONER	\$ 253,836	\$ 49,831	19.6%	80.4%
52	01150	TAX ASSESSOR	\$ 318,824	\$ 60,017	18.8%	81.2%
53	01565	GOV'T BUILDINGS	\$ 166,088	\$ 46,918	28.2%	71.8%
54	80000	DEBT SERVICE	\$ 429,296	\$ 110,044	25.6%	74.4%
55		TOTAL GENERAL GOVERNMENT	\$ 2,041,632	\$ 441,289	21.6%	78.4%
	200	JUDICIAL-				
56	02150	SUPERIOR COURT	\$ 409,023	\$ 88,782	21.7%	78.3%
57	02200	DISTRICT ATTORNEY	\$ 57,036	\$ 8,803	15.4%	84.6%
58	02400	MAGISTRATE COURT	\$ 138,836	\$ 33,391	24.1%	75.9%
59	02450	PROBATE COURT	\$ 202,262	\$ 33,217	16.4%	83.6%
60	02600	JUVENILE COURT	\$ 5,000	\$ 542	10.8%	89.2%
61	03100	COURTS: OTHER COSTS	\$ 117,866	\$ 28,786	24.4%	75.6%
62		TOTAL JUDICIAL	\$ 930,023	\$ 193,521	20.8%	79.2%
	300	PUBLIC SAFETY-				
63	03300	SHERIFF	\$ 2,536,643	\$ 478,209	18.9%	81.1%
64	03326	JAIL	\$ 1,015,987	\$ 212,536	20.9%	79.1%
65	03360	COURTHOUSE SECURITY	\$ 113,563	\$ 21,618	19.0%	81.0%
66	03550	FIRE RESCUE	\$ 1,296,952	\$ 271,236	20.9%	79.1%
67	03700	CORONER	\$ 25,895	\$ 5,776	22.3%	77.7%
68	03900	ANIMAL CONTROL	\$ 157,474	\$ 29,193	18.5%	81.5%
69	03920	EMERGENCY MANAGEMENT	\$ 14,463	\$ 1,478	10.2%	89.8%
70		TOTAL PUBLIC SAFETY	\$ 5,160,977	\$ 1,020,045	19.8%	80.2%
71	400	PUBLIC WORKS-ROADS AND BRIDGES	\$ 2,007,719	\$ 445,584	22.2%	77.8%
	600	CULTURE/RECREATION-				
72	06100	RECREATION-	\$ 292,575	\$ 58,654	20.0%	80.0%
73	06200	SENIOR CENTER	\$ 254,633	\$ 57,808	22.7%	77.3%
74		TOTAL CULTURE/RECREATION	\$ 547,208	\$ 116,462	21.3%	78.7%
	700	HOUSING DEVELOPMENT-				
75	07100	COUNTY EXTENSION SERVICE	\$ 66,887	\$ 5,515	8.2%	91.8%
76	07410	PLANNING AND ZONING	\$ 261,023	\$ 67,304	25.8%	74.2%
77		TOTAL HOUSING AND DEVELOPMENT	\$ 327,910	\$ 72,819	22.2%	77.8%

JASPER COUNTY BOARD OF COMMISSIONERS  
 FY2022 1ST QUARTER  
 FINANCIAL REPORT  
 JUNE 30, 2022

			FY 2022 BUDGET	FY 2022 ACTUAL	%	%
100	GENERAL FUND -				EXPENDED	UNENCUMBERED
DEPT #	EXPENDITURES					
900	APPROPRIATIONS/CONTINGENCY-					
78	572015	JASPER MEMORIAL HOSPITAL	\$ 14,000	\$ 2,257	16.1%	83.9%
79	572030	DEPT OF FAMILY AND CHILDRENS SERVICES	\$ 10,375	\$ 2,594	25.0%	75.0%
80	572060	CONSERVATION	\$ 3,000	\$ 750	25.0%	75.0%
81	572070	JC BOARD OF EDUCATION	\$ 32,500	\$ 3,520	10.8%	89.2%
82	572080	PUTNAM-JASPER SUPPORT SERVICES	\$ 5,760	\$ 1,440	25.0%	75.0%
83	572100	AZALEA REGIONAL LIBRARY	\$ 96,943	\$ 24,236	25.0%	75.0%
84	572101	AZALEA REGIONAL LIBRARY - 2% LOST	\$ 17,500	\$ 3,612	20.6%	79.4%
85	572110	GA FORESTRY	\$ 15,876	\$ 15,876	100.0%	0.0%
	572175	PUBLIC FACILITY AUTHORITY	\$ 10,000	\$ 2,600	26.0%	74.0%
86	572179	FAMILY CONNECTION	\$ 8,500	\$ 2,125	25.0%	75.0%
87	572180	FAMILY CONNECTION	\$ 48,000	\$ 8,000	16.7%	83.3%
88	572190	CHAMBER OF COMMERCE	\$ 44,000	\$ 11,000	25.0%	75.0%
89	572200	FOUR COUNTY DEV AUTHORITY	\$ -	\$ -		
90	573000	JCSWA	\$ 42,900	\$ -	0.0%	100.0%
91	579000	CONTINGENCY & PAYROLL CONTINGENCY	\$ -	\$ -		
92	579200	911 AUTH PAYROLL CONTINGENCY	\$ -	\$ -		
93		TOTAL APPROPRIATIONS/CONTINGENCY	\$ 349,354	\$ 78,009	22.3%	77.7%
	950	COMPONENT UNITS-				
94	611200	JASPER COUNTY HEALTH DEPARTMENT	\$ 57,517	\$ 14,379	25.0%	75.0%
95	611300	ECONOMIC DEVELOPMENT AUTHORITY	\$ 107,513	\$ 26,878	25.0%	75.0%
96	611400	E911 JOINT COUNTY AUTHORITY	\$ 362,715	\$ 90,679	25.0%	75.0%
97	612500	TRANSFER TO SENIOR CENTER	\$ -	\$ -		
98	612540	TRANSFER TO LANDFILL	\$ 159,780	\$ 39,945	25.0%	75.0%
99	618000	TRANSFER FROM CURBSIDE	\$ (14,102)	\$ (3,526)	25.0%	75.0%
100		TOTAL COMPONENT UNITS	\$ 673,423	\$ 168,356	25.0%	75.0%
101	600010	CAPITAL TRANSFER	\$ -	\$ -		

**Agenda Request – Jasper County BOC**

**Department:** Board of Commissioners

**Date:** November 1, 2021

**Subject:** Schedule Work Sessions and Called Meetings As Needed

**Summary:**

Schedule work sessions and called meetings as needed.

**Background:**

**Cost:**

**Recommended Motion:**

Board Discretion